

DOMINATOR*PLUS*

User, Installation and Servicing Instructions

GAS FRYERS

G3860F & G3865F

Read these instructions before use.

DATE PURCHASED:

MODEL NUMBER:

SERIAL NUMBER:

DEALER:

SERVICE PROVIDER:

T101116

Rev No: 1
Published: 20/08/2024

Dear Customer

Thank you for choosing Falcon Foodservice Equipment.

This manual can be downloaded from www.falconfoodservice.com or scan here:



IMPORTANT: Please keep this manual for future reference.

Falcon Foodservice Equipment

HEAD OFFICE

Wallace View, Hillfoots Road, Stirling. FK9 5PY. Scotland.

01786 455200

PREVENTATIVE MAINTENANCE CONTRACT

To obtain maximum performance from this unit regular servicing of the appliance should be undertaken to ensure correct operation, it is functioning as intended, and safe to use. We recommend servicing in accordance with SFG20 Maintenance Schedules and as a minimum, after 2,500 hours of use, or annually, whichever comes first and that a maintenance contract be arranged with an appointed service contact. Visits may then be made at agreed intervals to carry out adjustments and repairs.



WEEE Directive Registration No. WEEE/DC0059TT/PRO

At end of appliance life, dispose of appliance and any replacement parts in a safe manner, via a licensed waste handler. Appliances are designed to be dismantled easily and recycling of all material is encouraged whenever practicable.

CONTENTS

1.0	SYMBOLS & LABELS	5
2.0	SAFETY GUIDANCE	6
2.1	GENERAL SAFETY.....	6
2.2	INSTALLATION SAFETY.....	7
2.3	ELECTRICAL SAFETY.....	8
2.4	GAS SAFETY	8
2.5	FIRE SAFETY.....	8
2.6	MAINTENANCE SAFETY	10
3.0	APPLIANCE INFORMATION	12
4.0	OPERATION AND CULINARY GUIDANCE	13
4.1	G3860F COMPONENT PARTS.....	13
4.2	G3865F COMPONENT PARTS.....	14
4.3	CONTROLS.....	15
4.4	USING THE APPLIANCE	16
4.5	FILTRATION.....	19
4.6	SAFETY RESET	20
4.7	CULINARY GUIDANCE	21
5.0	CLEANING AND MAINTENANCE	22
6.0	SPECIFICATION	25
6.1	APPLIANCE WEIGHT TABLE	25
6.2	ELECTRICAL DATA TABLE	25
6.3	INJECTOR SIZES & PRESSURE TABLE.....	25
6.4	HEAT INPUT TABLE	26
7.0	DIMENSIONS / CONNECTION LOCATIONS	26
7.1	G3860F FRYER.....	26
7.2	G3865F FRYER.....	27
8.0	INSTALLATION	27
8.1	SITING / CLEARANCES.....	28
8.2	VENTILATION	28
8.3	ASSEMBLY	29
8.4	GAS SUPPLY & CONNECTION.....	30
8.5	ELECTRIC SUPPLY & CONNECTION	30

8.6	COMMISSIONING	31
9.0	CONVERSATION	32
9.1	GAS CONVERSION CHECK LIST	32
10.0	SERVICING	33
10.1	CONTROL PANEL	34
10.2	SAFETY THERMOSTAT	35
10.3	PIEZO IGNITER AND SPARK ELECTRODE	37
10.4	GAS VALVE	38
10.5	PILOT ASSEMBLY.....	41
10.6	BURNER	42
10.7	PUMP SWITCH.....	43
10.8	PUMP.....	44
10.9	PUMP TIMER SETTING	47
10.10	GOVERNOR	47
10.11	WIRING DIAGRAMS	48
11.0	ACCESSORIES.....	52
11.1	SPLASHGUARD	52
12.0	FAULT FINDING	53
13.0	SPARE PARTS	54

1.0 SYMBOLS & LABELS



SCREWDRIVER



SPANNER



COOKING OIL



GREASE



WARNING

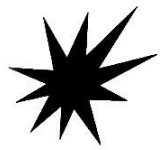

SPARK IGNITION



FLAME



VIEWPORT



ALLEN KEY



IGNITER



C SPANNER



REMOVE DEVICE



PLUG
REMOVER



WARNING
ELECTRICITY



READ MANUAL



FIRE RISK

2.0 SAFETY GUIDANCE

2.1 GENERAL SAFETY



2.1.1 These instructions are only valid if the country code appears on the appliance. If the code does not appear on the appliance, refer to the technical instructions for adapting the appliance to the conditions for use in that country.

2.1.2 These appliances have been UKCA/CE-marked based on compliance with the Product Safety and Metrology Regulations/Gas Appliance Regulations, Electrical/LVD and Electromagnetic Compatibility (EMC) Regulations/Directives for the Countries, Gas Types and Pressures as stated on the data plate.



2.1.3 This equipment is for professional use only and must be used by qualified persons.

2.1.4 Never leave this appliance unsupervised when in use and always turn appliance off at the end of service.



2.1.5 The installer must instruct the responsible person(s) of the correct operation and maintenance of the appliance.

2.1.6 Check that no damage has occurred to the appliance or supply cord during transit. If damage has occurred, do not use this appliance.



2.1.7 If fitted to the appliance, ensure the supply cord is routed free from the appliance to avoid damage.

2.1.8 Min-Level Mark: Oil should never be allowed to drop below the mark. Should this occur, top up immediately or switch off the fryer.



2.1.9 Suitable Protective clothing must be worn when topping up whilst the fryer is hot.

2.1.10 To prevent surge boiling. DO NOT EXCEED recommended loads or charge pan with over-wet food items. NEVER leave a working appliance unattended.

2.1.11 If the appliance is fitted with an oil bucket, take care when removing as oil bucket is heavy when full.

2.1.12 Training and Competence: To help ensure the safe use of this appliance there is a requirement for you to provide whatever information, instruction, training, and supervision as is necessary to ensure, so far as is reasonably practicable, the health and safety of all users.

2.1.13 For further help and information on training and competence we refer you to the Health & Safety Executive website; www.hse.gov.uk document ref: health and safety training INDG345. International customers should default to the health and safety guidelines provided by your government body.



2.1.14 Risk Assessment: As part of managing the health and safety of your business you must control any risks identified in your commercial kitchen. To do this you need to think about what might cause harm to people and decide whether you are taking reasonable steps to prevent that harm. This is known as risk assessment. It is important to consider the environment around the product as well as the product itself. For example, oil or food spills will present a significant risk so users so the need to immediately clean up such spills must be reflected in staff training.

2.1.15 Record the training that you provide and support it by providing safe system of work (SSOW) documents that set out procedures to be followed for potentially hazardous tasks.

2.1.16 For further help and information on risk assessments we would refer you to you the Health and Safety Executive website; www.hse.gov.uk document ref: risk assessment INDG163. International customers should default to the health and safety guidelines provided by your government body.

2.2 INSTALLATION SAFETY



2.2.1 Installation must meet national or local regulations. Attention must be paid to safety (installation & use) regulations, health and safety at work act, local and national building regulations, fire precautions act.

2.2.2 The installer must instruct the responsible person(s) of the correct operation and maintenance of the appliance.

2.2.3 On gas appliances, only competent persons are allowed to service or convert the appliance to another gas type.

2.2.4 Put a documented system in place for periodic inspections, testing and maintenance of our gas/ electrical appliances. Check that the fixed electrical installation has been inspected and tested by a competent electrical contractor (e.g. NICEIC-approved or ECA member) as prescribed in BS7671, within the last 5 years.

2.3 ELECTRICAL SAFETY



2.3.1 To prevent shocks, this appliance must be earthed.

2.3.2 This unit is fitted with an equipotential connection at the rear on the base.

2.3.3 Before attempting any maintenance, isolate the appliance at the mains switch and take steps to ensure that it is not inadvertently switched on.

2.3.4 We recommend, Supplementary electrical protection with the use of a type A residual current device (RCD).

2.3.5 Fixed wiring appliances incorporate a locally situated switch disconnecter.

2.3.6 to connect to, which is easily accessible for switching off and safe isolation purposes. The switch disconnecter must meet the specification requirements of IEC 60947.

2.4 GAS SAFETY



2.4.1 Gas appliances must have a stop cock fitted in the supply pipe work. The user must be familiar with the location and operation of this device in order to turn off the supply of gas in the event of an emergency.

2.4.2 Before Inspection, Servicing or Conversion, Turn Off Gas at isolator.

2.5 FIRE SAFETY



Fryers can present various hazards in the catering environment if not correctly used, operated, and maintained. Hazards including fire, burns from hot oil, contact with hot surfaces, fumes from boiling cleaning chemicals, eye injuries from splashes and slips from oil spillages.

Operator Competency and Training

- 2.5.1 Ensure you are trained in the safe and proper use of the fryer and know how to turn it off and switch the power or gas off at the mains.
- 2.5.2 Ensure you are familiar with the kitchen fire safety procedures and the location and proper use of correct fire safety equipment.

Fryer Safety Equipment

- 2.5.3 Provide an appropriate BS compliant fire blanket, and an adequate number of fire extinguishers that comply with BS EN 3 (parts 1-6) and carry a BAFE or LPCB approval mark. At least one must be appropriate for use on electrical fires, and one for deep-fat fryers (Class F).

Fryer Suppression System

- 2.5.4 We recommend kitchen equipment and extraction systems are protected with a fire suppression system. Check your insurance as this may also be a condition of your policy.
- 2.5.5 Protect cooking and extraction equipment (including any associated extraction ductwork and hoods inside the building) by having an extinguishing system installed, in line with (or the equivalent of) [LPS 1223](#). The system should include a local alarm, automatic activation by a detection system and manual activation – located a safe distance away from the cooking equipment, preferably by a fire escape route door.

Operational Fryer Safety

- 2.5.6 Do not leave the fryer unattended when powered on or when it is in use.
- 2.5.7 Always switch the fryer off and replace the pan cover/ lid when not in use.

Cleaning

- 2.5.8 Ensure fryers are regularly cleaned serviced and maintained by a qualified and competent service provider, and there is enough room around the appliance to do so.
- 2.5.9 Ensure that the appliance, surrounding work area and extraction system are regularly cleaned, (at least weekly) to avoid the build-up of fats oils and greases that could present a fire risk. A deep clean should be undertaken at least every 6 months by a specialist contractor.

Oil Safety

2.5.10 Do not operate the fryer with no or low oil levels.

2.5.11 We do not recommend using Solid Fat with these fryers as control does not have a Fat Melt Cycle.

2.5.12 Regularly change your cooking oil. Use colour charts to check on oil quality.



2.5.13 If you see the cooking oil or fat smoking, switch the fryer off, allow to cool, drain oil, clean and dry fryer pan thoroughly and replace with fresh oil. If the clean fryer oil smokes when heated, switch off immediately and contact service engineer. Do not switch fryer back on.

2.5.14 Never add water to the fryer medium at any time.

Gas and Electrical Isolation Points

2.5.15 Ensure any separate gas shut off switches and electric switches provided for cooking equipment and/or extractor fans are accessible and clearly labelled.

Care and Maintenance of Thermal and Operational Safety Devices

2.5.16 Your fryer is fitted with a thermal safety device. This will stop heating of oil if it becomes overheated. This appliance will always fail safe so long as there is no damage to the thermal safety device.



2.5.17 Failure to clean and check the safety and operational thermostats can impact the performance of the appliance and increase the risk of an appliance fire.

2.5.18 Damage to the thermostat sensors or their capillaries can increase the risk of overheating or fire.

2.5.19 Do not operate the fryer if the safety devices located within the fryer pan appear to be dislodged or damaged.

2.6 MAINTENANCE SAFETY



2.6.1 Unless otherwise stated, parts which have been protected by the manufacturer must not be adjusted by the installer or end user.



2.6.2 Before any cleaning is undertaken, isolate appliance from mains power supply at isolator switch.

2.6.3 Suitable protective clothing must be worn when cleaning this appliance.



2.6.4 If filtration is fitted, never pump water through the filtration pump at any time! Water and hot oil are an explosive mixture.

2.6.5 Oil must be allowed to cool to a safe temperature before draining. Do not overfill the oil bucket. All spills onto the appliance and on the floor should be cleaned up immediately

2.6.6 The appliance must not be cleaned with a jet of water or steam cleaned. Do not use acid or halogen-based (e.g., chlorine) descaling liquids, flammable liquids, cleaning aids or cleaning powders.

2.6.7 Failure due to lack of proper cleaning is not covered by warranty.

2.6.8 Particular attention must be paid to cleaning the Thermostat bulb & Capillaries.



2.6.9 Take care when cleaning not to dislodge or damage thermostat sensors mounted on the base and side of the pan.



2.6.10 If the thermostats or capillaries are damaged, then do not turn the appliance on. Contact Falcon or you approved service provider to undertake the necessary repairs.



2.6.11 To obtain maximum performance from this unit regular servicing of the appliance should be undertaken to ensure correct operation, it is functioning as intended, and safe to use. We recommend servicing in accordance with SFG20 Maintenance Schedules and as a minimum, after 2,500 hours of use, or annually, whichever comes first and that a maintenance contract be arranged with an appointed service contact. Visits may then be made at agreed intervals to carry out adjustments and repairs.



2.6.12 During Servicing of the appliance, where applicable, please ensure seals are checked. If the integrity of the seal is compromised, it must be replaced

3.0 APPLIANCE INFORMATION

This appliance has been UKCA/CE-marked on the basis of compliance with the Product Safety and Metrology Regulations/Gas Appliance Regulations, Electrical/LVD and Electromagnetic Compatibility (EMC) Regulations/Directives for the heat inputs, gas pressures and voltages stated on the data plate.

Falcon Foodservice Equipment 	STD .	MODEL xxx .	SERIAL NO. Fxxxxxx	GAS TYPE .				
	SUPPLY PRESS . mbar	COUNTRY .	P.I.N .	CAT .				
		SAMPLE			I P R .			
	INJECTOR MARKING				HEAT INPUT	kW	GAS RATE	ADJ PRESS . mbar
						kW	m ³ /h	SET PRESS OVEN . mbar
			kW	kg/h	SET PRESS BOILER . mbar			
	RATED ELECTRIC INPUT . kW	VOLTS .	OUTPUT FREQ . kHz	EXT FUSE . A				
	PHASE LOADING	L1 -A	L2 -A	L3 -A	Hz INT FUSE . A			
SCRAP			MODEL xxx	Fxxxxxx				

4.0 OPERATION AND CULINARY GUIDANCE

4.1 G3860F COMPONENT PARTS.

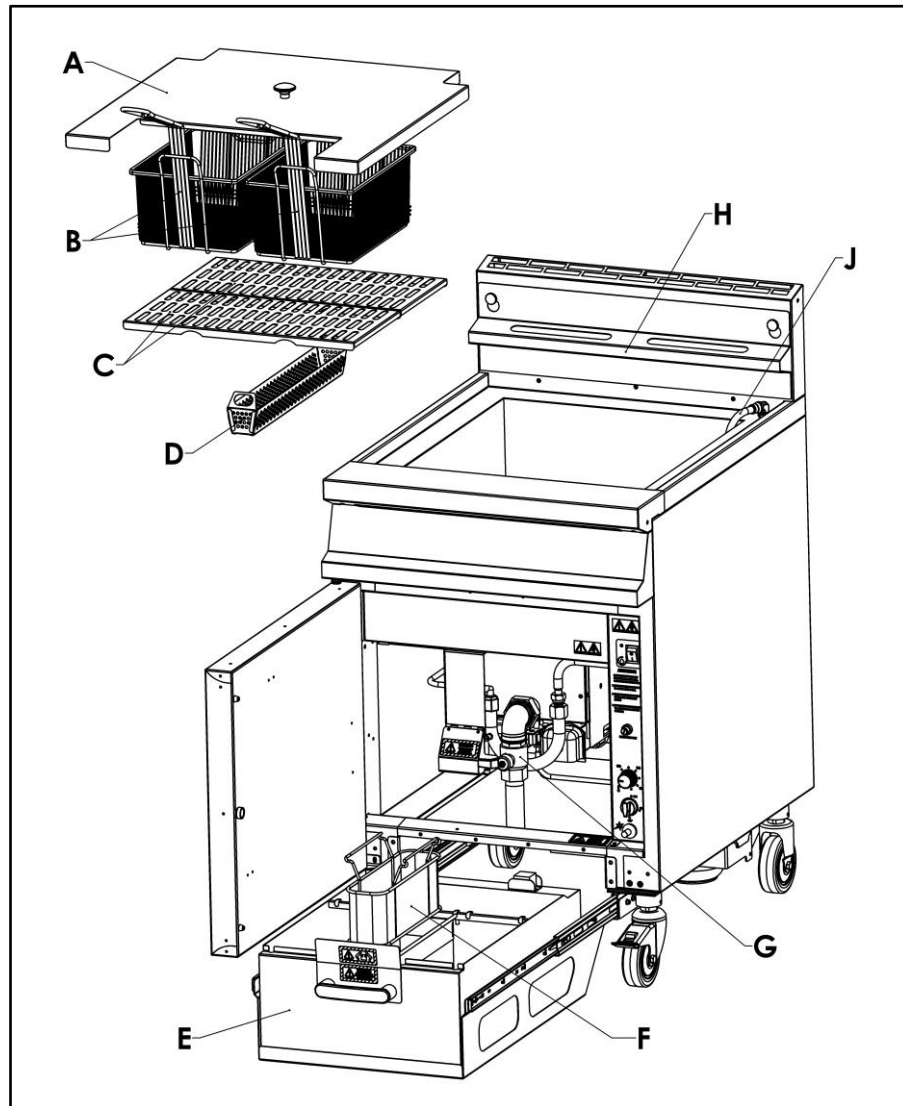

A - Dust Cover

B - Basket

C - Fry Plates

D - Crumb Catcher

E- Oil Bucket

F - Filtration Basket & Mesh Filter

G - Drain Valve

H - Basket Hanger

J - Oil Return Pipe

4.2 G3865F COMPONENT PARTS.

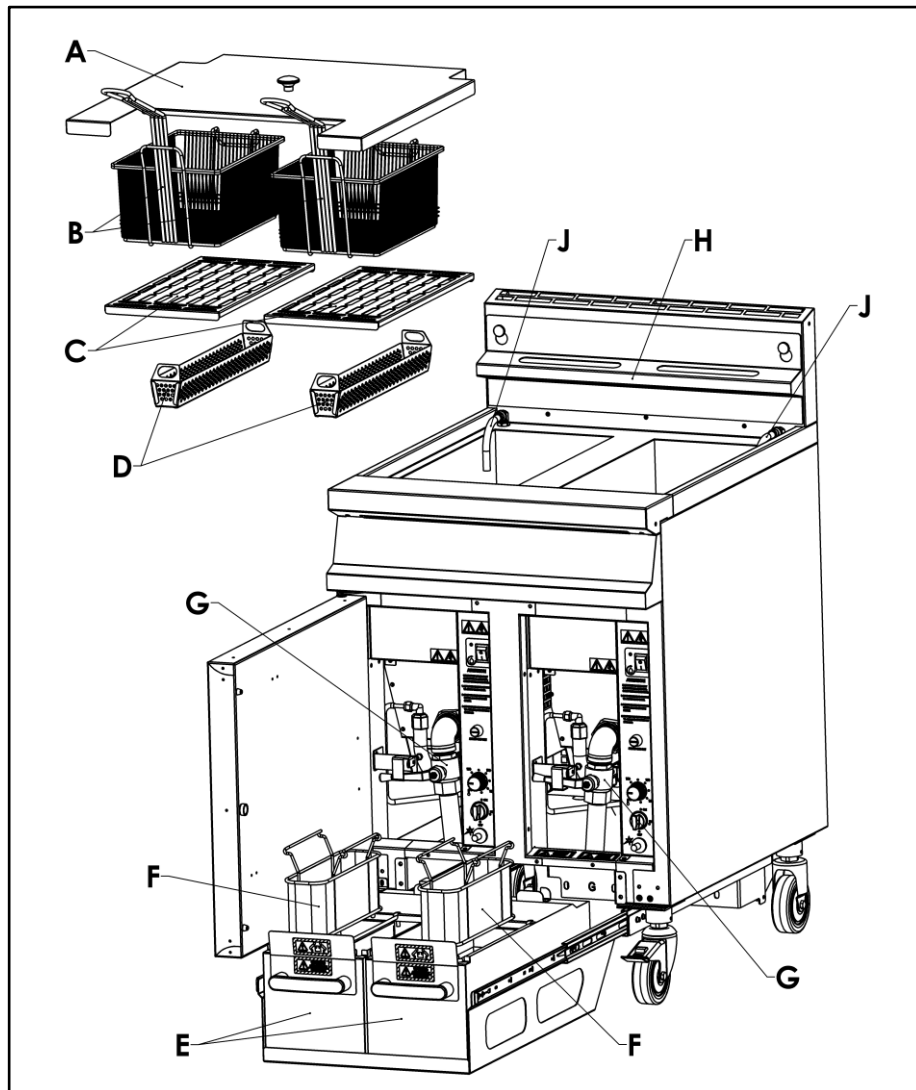

A - Dust Cover

B - Baskets

C - Fry Plates

D - Crumb Catchers

E - Oil Buckets

F - Filtration Baskets & Mesh Filters

G - Drain Valves

H - Basket Hanger

J - Oil Return Pipes

4.3 CONTROLS.

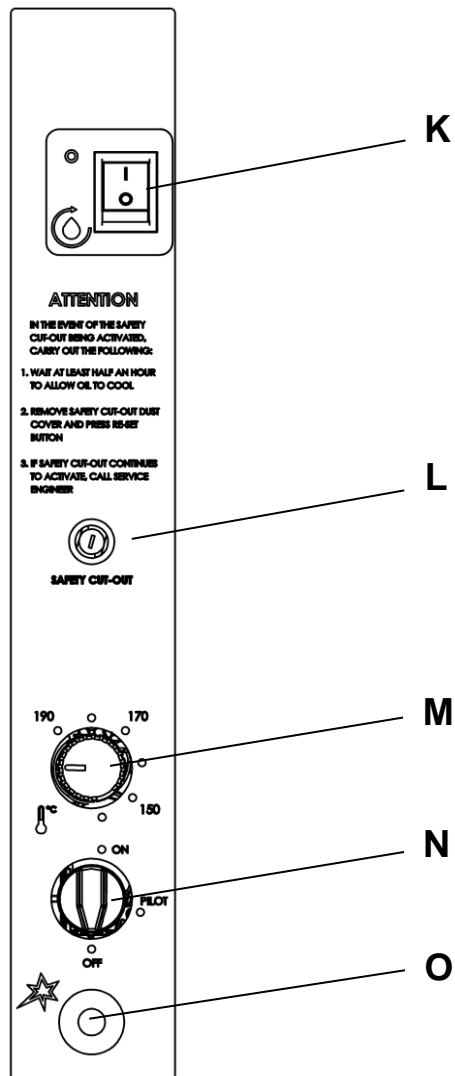

K - Pump Switch

L - Safety Thermostat Reset Button

M - Temperature Control

N - Gas Control

O - Piezo Igniter

4.4 USING THE APPLIANCE

4.4.1 Always clean the appliance before use. See section 5.0.



PARTICULAR ATTENTION MUST BE PAID TO CLEANING THE THERMOSTAT BULB AND CAPILLARIES.

ENSURING FOOD DEBRIS DOES NOT BUILD UP, WHICH COULD DETRIMENTALLY AFFECT THE PERFORMANCE AND SAFETY OF THE APPLIANCE.



NEVER STORE MATERIALS THAT ARE SUSCEPTIBLE TO HEAT UNDER THE BURNER INSIDE THE APPLIANCE.

NEVER ADD COOKING OIL TO A FRYER IF IT IS NOT COMPLETELY DRY OF WATER. DOING SO CAN LEAD TO EXPLOSION OF HOT COOKING OIL.

4.4.2 Ensure the **drain valve** is closed, the **pump switch** is in **OFF** position, and fill the pan with **cold** good quality vegetable oil to the level indicated by the **lower strip on rear of pan (MIN)**. This level is the maximum cold fill mark to achieve the stated performance of the fryer. The volume of oil will increase as the oil is heated and rise to the **hot** oil mark above **(MAX)**.

The approximate volume of cold oil, when filled to the **MIN** level is:

G3860F	24 Litres
G3865F	2 x 15 litres

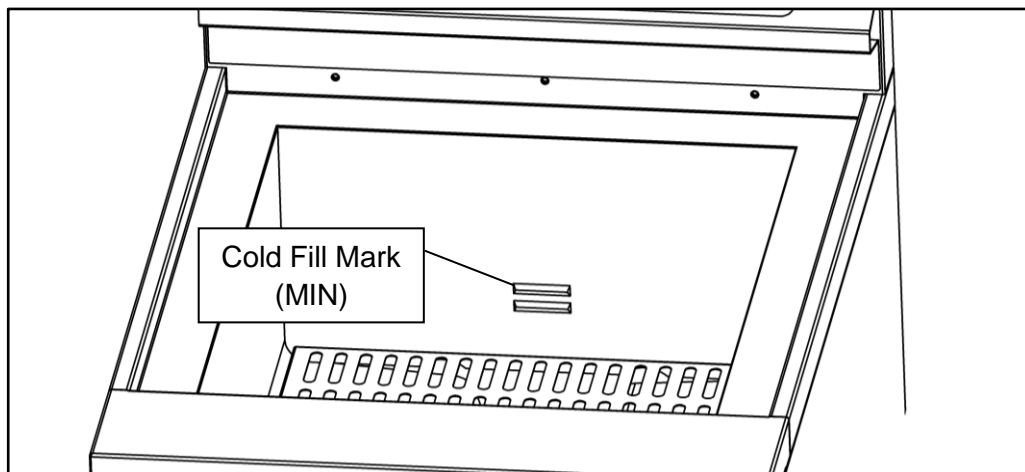

ALWAYS MAINTAIN AN OIL LEVEL BETWEEN MAX AND MIN LEVELS INDICATED ON FRY PLATE.



WHEN HOT, THE COOKING MEDIUM MUST NEVER BE ALLOWED TO DROP BELOW THE MIN LEVEL AS THIS WILL LEAD TO AN UNSAFE SITUATION.

IF THIS HAPPENS THE OIL MUST BE TOPPED UP BEFORE CONTINUING TO USE THE FRYER.

NEVER ALLOW OIL TO GO ABOVE MAX LEVEL WHEN UNLOADED AS THIS MAY CAUSE THE OIL TO OVERFLOW FROM THE PAN WHEN FOOD IS DROPPED IN.



SUITABLE PROTECTIVE CLOTHING AND ALL CARE NECESSARY MUST BE USED WHEN TOPPING UP A HOT FRYER.

IT IS RECOMMENDED THAT REPLENISHMENT OF THE OIL TAKES PLACE WHEN THE FRYER IS COOL.

To heat the oil, ensure **pump switch remains OFF**:

4.4.3 Turn **gas control** to the **PILOT** **1** position and push the **gas control knob** in.

4.4.4 While still holding the **gas control knob** in the **PILOT** **1** position, repeatedly press the **piezo igniter** **2** until the pilot burner lights.

4.4.5 Once the pilot flame can be seen **3**, continue to hold the **gas control knob** in for a further 20 seconds. Pilot should remain lit when knob is released. If not, repeat ignition procedure.

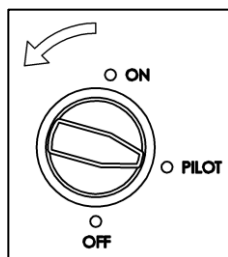
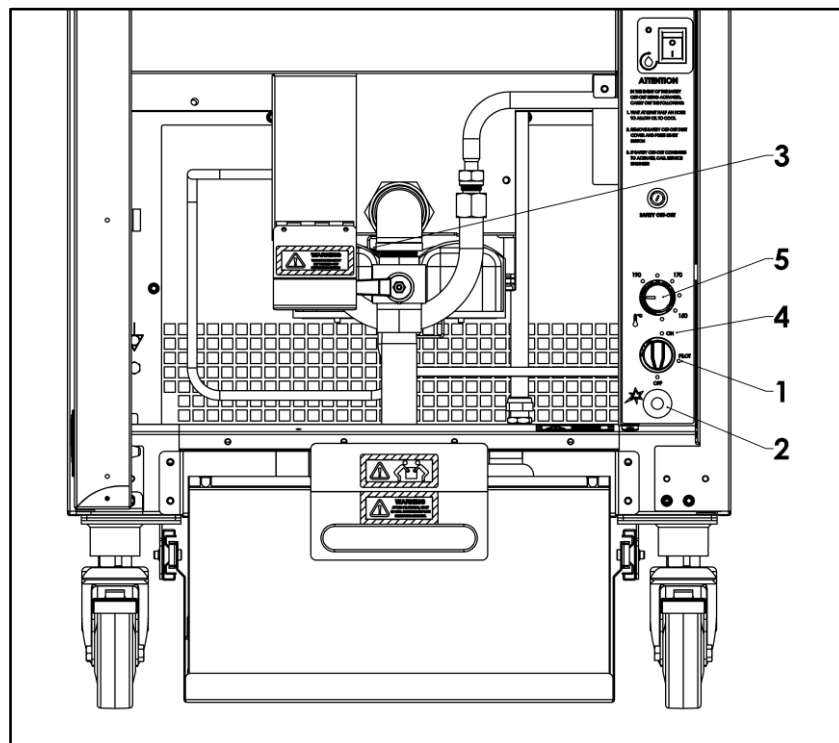

Ignition/Pilot only

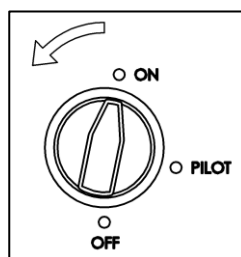

Pilot and Main Burner ON

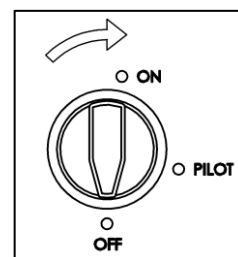

Pilot and Main Burner OFF

4.4.6 When ready to cook, turn the **gas control** to the **ON**⁴ position. Set the **temperature control**⁵ as required between 140°C and 190°C.



APPLIANCES THAT ARE IN USE MUST BE SUPERVISED AT ALL TIMES.



OIL SHOULD NOT BE OVERHEATED AS THIS WILL INCREASE THE RISK OF FIRE

FRYER IS FITTED WITH A THERMAL SAFETY DEVICE. THIS WILL STOP HEATING OF OIL IF IT BECOMES OVERHEATED. THIS APPLIANCE WILL ALWAYS FAIL SAFE.

4.4.7 To turn the main burner off, turn the **gas control** to **PILOT**¹ position. To turn the appliance off completely (main burner and pilot), turn gas control knob to **OFF** position.

4.4.8 **G3860F/G3865F Draining** – Draining old oil must be done after the oil has been allowed to cool. Ignoring this advice may lead to burns and build-up of oily condensation inside the appliance.

Ensure oil bucket is in position and the pump switch is in OFF position.

The drain valve is behind safety cover plate. Lift the safety panel ¹ up to gain access to handle, then turn valve handle ² to drain oil into the supplied **oil buckets**. The **oil buckets** can then be removed, and the oil transferred to a suitable disposal container. Any large pieces of debris will be captured by the crumb catcher.

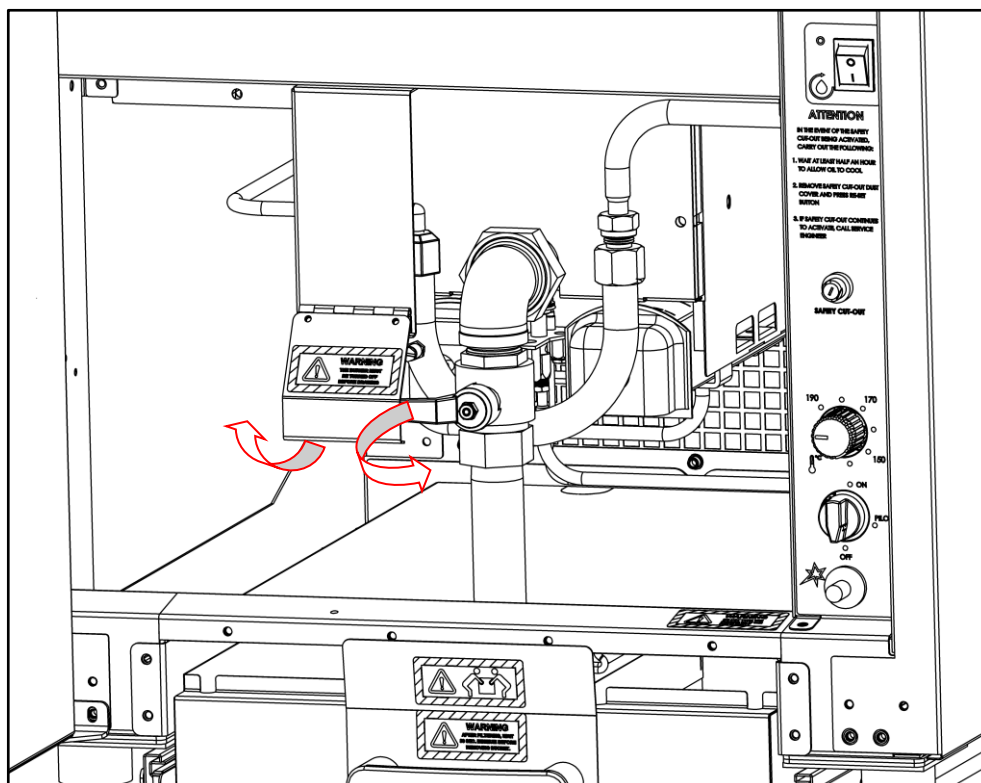



THE DRAIN VALVE MUST ONLY BE OPERATED WHEN THE GAS CONTROL IS SET TO OFF. NOT FOLLOWING THIS PART OF THE PROCEDURE WILL LEAD TO THE RESIDUAL OIL IN THE FRYER CATCHING FIRE.



ENSURE OIL BUCKET IS IN POSITION. THE OIL BUCKET MAY BE HOT AND HEAVY WHEN FULL OF OIL. TAKE CARE WHEN REMOVING.



ENSURE THE FILTRATION BASKETS AND MESH FILTER ARE CLEANED REGULARLY. FAILURE TO DO SO MAY CAUSE THE OIL TO OVERFLOW FROM THE OIL BUCKET.

4.5 FILTRATION

4.5.1 The oil will not pump back into the pan unless the **oil bucket(s)** and the oil-pick up pipe(s) are in the correct position. The oil pick-up pipe must face towards the back of the unit.

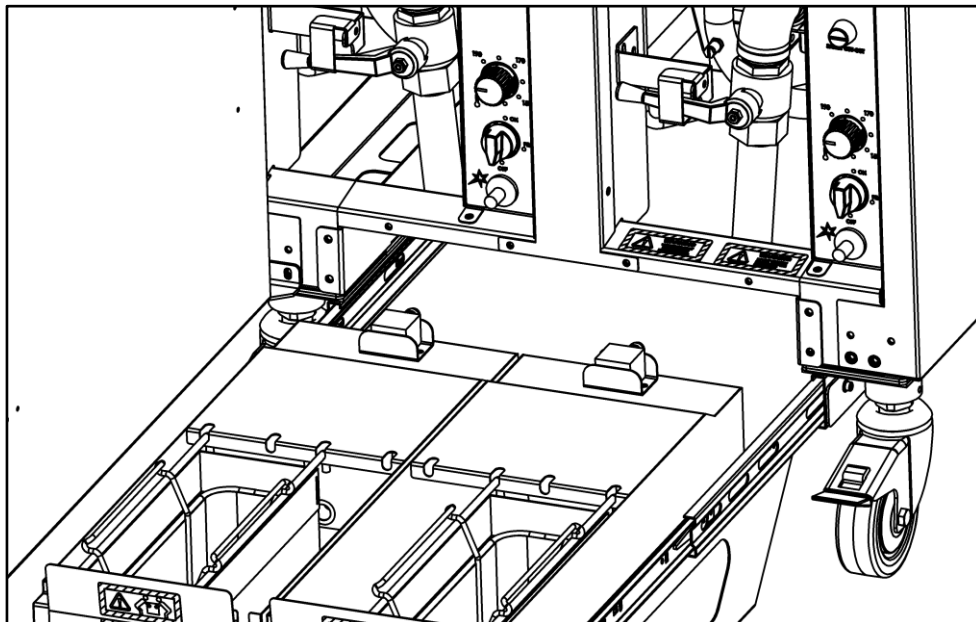

4.5.2 Ensure **gas control** is in the **OFF** **1** position and allow oil to cool for 15 to 20 minutes. Drain the oil into the **oil buckets** and switch on the filtration system using the **pump switch** **2**. Let the oil cycle through the provided **filtration basket** and **mesh filter** to clear the debris within the oil. The appliance is designed so that the pump will cut-off after operating for 8 minutes. To continue with the filtration process, simply reactivate the **pump switch**.

4.5.3 When oil and pan are free from debris close the drain valve to re-fill the fryer pans with oil to correct level. Top-up with clean oil within the MIN-MAX level if needed.

After filtering wait 30 seconds before removing the **oil bucket**.

4.6 SAFETY RESET

4.6.1 The **safety thermostat** is to prevent fire in the event of an operating thermostat failure and will prevent the main burners from working. If the burners don't turn on, it may be due to the safety cut-out and the safety thermostat will need to be reset.

4.6.2 To reset the safety thermostat, first ensure the **gas control** is turned **OFF** and wait at least half an hour for the oil to cool. Remove the black dust cover and press the safety thermostat reset button as shown below.

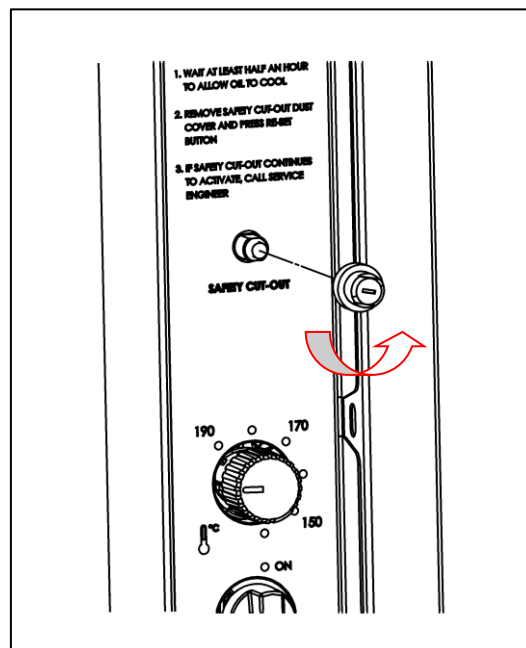

IF SAFETY CUT-OUT CONTINUES, A QUALIFIED ENGINEER MUST INVESTIGATE THE CAUSE.

4.7 CULINARY GUIDANCE



CARE MUST BE TAKEN WHEN INTRODUCING FROZEN OR WET PRODUCT INTO HOT OIL TO PREVENT SURGE BOILING.

OLD OIL WILL HAVE A REDUCED FLASH-POINT AND BE PRONE TO SURGE BOILING.

WATER MUST NEVER BE INTRODUCED INTO HOT OIL.



OVERLOADING THE BASKETS WILL AFFECT THE FRYER PERFORMANCE.

SETTING THE OIL TEMPERATURE ABOVE THE RECOMMENDED VALUE MAY REDUCE THE LIFE OF OIL.

NEVER LEAVE A WORKING UNIT UNATTENDED.

- Take additional care when frying wet products or items from frozen, to prevent surge boiling.

Where applicable in accordance with food product to be fried, allow food to thaw slightly prior to adding to hot oil to avoid increased thermal shock to oil.

Adjust frying temperature and frying times in accordance with food type, condition i.e. fresh chilled or frozen, battered or crumbed, etc.

Frying at correct temperatures will enhance food appearance and eating qualities, as well as extend the life and safe usability of the oil.

Regular oil skimming must take place during frying, by using a spider or long handle sieve scoop to get rid of floating food debris. Failing to skim, will create an eventual discoloration/darkening of the oil. Which will affect food quality, flavour and appearance.

150° - 175°C is a good frying temperature range.

- Delicate 150 - 160°C such as crispy vegetables
- Crumbed frozen 155 - 160°C
- Crumbed fresh 160°C
- Battered fresh 165 - 170°C
- Tempura 160 - 165°C
- Spring rolls 165 - 170°C fresh or frozen
- Wontons 165 - 170°C fresh or frozen
- Samosas 160 - 165°C
- Chips thin fresh 170°C
- Chips thin frozen 160 - 165°C
- Chips thick fresh 150 - 170°C
- Chips thick frozen 160 - 165°C

Never decant frozen, breaded / crumbed products directly into basket over oil in tank. It is advised to use appropriate trays with fryer basket in them, and then to fill with above products. Giving the baskets a good, few, shakes, will eliminate the excess crumbs and avoid from additional food debris contamination in oil.

- Fresh oil is best. Replace oil regularly, as old oil has a lower flash point which will lead to eventual surge boiling.
- Using old oil further affects performance and adversely affects food quality, fry times and food output.
- Do not overload the baskets and or fryer. Check the maximum allowed weight prescribed for the specific basket used – i.e. 1.5kg or 1.8kg chilled chips per basket.

A rough guide would be to fill the basket halfway which would equate to the maximum volume approximately.

- Fryers when in operation / on, should never be left unattended.
- Water or any other liquid must never be stored near, above or in adjacent equipment, to fryers.

5.0 CLEANING AND MAINTENANCE

MAINTENANCE CHECK

Regular servicing of the appliance should be undertaken to ensure correct operation, it is functioning as intended, and safe to use. We recommend servicing after 2,500 hours of use, or annually, whichever comes first.

Any maintenance schedule should be carried out in accordance with SFG20 Maintenance Schedules. Should any issues with the integrity of the components be identified these should be replaced. If the appliance is not considered safe the unit should be removed from service and the responsible person advised why the unit is not safe to use and what remedial action is needed. Contents of the maintenance schedule should be agreed with the maintenance provider.

When removing heavy items to aid cleaning or maintenance particular care should be taken. A manual handling risk assessment is the best way to determine the level of risk to anyone using or maintaining this equipment. To help with such an evaluation we have included the weights of individual components that may present significant risk.

For further help and information on manual handling and associated risk assessment we would refer you to you the Health and Safety Executive website; www.hse.gov.uk document ref: manual handling at work INDG143. International customers should default to the health and safety guidelines provided by your government body.

The cleaning of fryers or other products that use hot oil present significant risks to end users and particular care should be taken. Cold water and hot oil for example are an explosive mix and should be avoided at all costs.

Other useful references for health and safety issues:

- www.hse.gov.uk
- Essentials of health and safety at work ISBN978
- Noise at work INDG362
- Safe systems of work
- Other notes added to the body of the instructions



BEFORE ANY CLEANING IS UNDERTAKEN, ISOLATE APPLIANCE FROM GAS SUPPLY AND MAINS POWER SUPPLY AT ISOLATOR SWITCH.

SUITABLE PROTECTIVE CLOTHING MUST BE WORN WHEN CLEANING THIS APPLIANCE.

NEVER PUMP WATER THROUGH THE FILTRATION PUMP AT ANY TIME.

OIL MUST BE ALLOWED TO COOL TO A SAFE TEMPERATURE BEFORE DRAINING. DO NOT OVERFILL OIL BUCKET.

THE APPLIANCE MUST NOT BE STEAM CLEANED. DO NOT USE ACID OR HALOGEN-BASED (E.G. CHLORINE) DESCALING LIQUIDS, FLAMMABLE LIQUIDS, CLEANING AIDS OR CLEANING POWDERS.

NEVER CLEAN PRODUCTS WHILST THEY ARE HOT – ALL SPILLS ON TO THE PRODUCT AREA OR THE FLOOR SHOULD BE CLEANED UP IMMEDIATELY

FAILURE DUE TO LACK OF PROPER CLEANING IS NOT COVERED BY WARRANTY.

Note: All surfaces are easier to clean if spillage is removed before it becomes burnt on, cleaned daily. Clean more often and better will result in less time wasted on heavier deep cleaning.

It should be noted that certain scouring pads including nylon types can easily mark stainless steel. Care should be exercised during cleaning process. When rubbing stainless steel with a cloth, always rub in grain direction.

5.1.1 Turn appliance off and cool down.

5.1.2 Drain oil as stated in section 4.4.8.

5.1.3 Filter oil as stated in section 4.5 then dispose the old oil.

5.1.4 Remove **baskets, fry plates** and **crumb catcher** and wash it in warm soapy water. Rinse and dry thoroughly before replacing them back in the appliance.

5.1.5 Ensure drain valve is closed and fill pan with warm soapy water to the oil level mark. Soak overnight if necessary and rinse with clean water before draining. Dry pan thoroughly.

5.1.6 Clean the safety and operating thermostats removing any food debris from around the thermostat sensors and protective guards which could detrimentally affect the performance and safety of the appliance.

TAKE CARE WHEN CLEANING NOT TO DISLODGE OR DAMAGE THERMOSTAT SENSORS MOUNTED ON THE BASE AND SIDE OF THE PAN.



DAMAGE TO THE THERMOSTAT SENSORS OR THEIR CAPILLARIES CAN INCREASE THE RISK OF OVERHEATING OR FIRE.

IF THE THERMOSTATS OR CAPILLARIES ARE DAMAGED THEN DO NOT TURN THE APPLIANCE ON. CONTACT FALCON OR YOU APPROVED SERVICE PROVIDER TO UNDERTAKE THE NECESSARY REPAIRS.

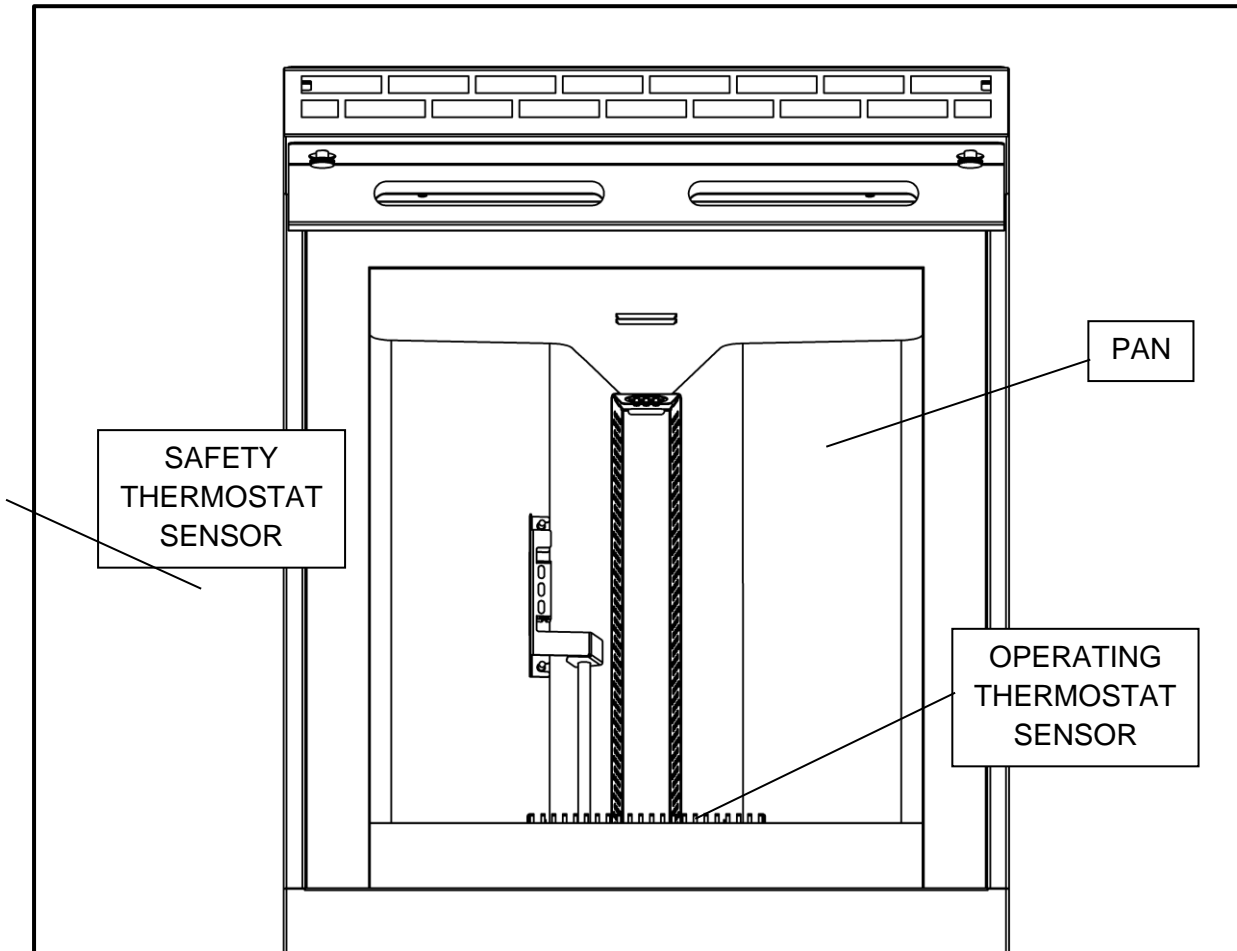

5.1.7 Remove all debris from the **filtration baskets** and **mesh filter**. Wash them with the **oil buckets** in warm soapy water.

5.1.8 Dry all components thoroughly before replacing them back in the appliance.



DO NOT RE-FILL OIL UNTIL THE PAN AND ALL COMPONENTS ARE COMPLETELY DRY, INCLUDING THE INSIDE OF THE DRAIN VALVE.

6.0 SPECIFICATION

6.1 APPLIANCE WEIGHT TABLE

APPLIANCE	UNIT WEIGHT (kg)	PACKED WEIGHT (kg)
G3860F	100	107
G3865F	136	147

These fryer models have no heavy lift-off components. The oil buckets will be heavy when containing oil.

6.2 ELECTRICAL DATA TABLE

APPLIANCE	PHASE	CURRENT			POWER
		MIN (A) @ 230V	MAX (A) @ 230V	ACTUAL (A) @ 230V	(kW) @ 230V
G3860F	L1	1.13	1.32	1.26	0.29
G3865F	L1	2.79	3.26	2.52	0.58



IF ANY CURRENT IS OUT WITH THESE TOLERANCES, THE CAUSE MUST BE INVESTIGATED AND RECTIFIED.

6.3 INJECTOR SIZES & PRESSURE TABLE

G3860F INJECTOR SIZES & PRESSURE			
		NATURAL GAS	PROPANE
G3860F		2 x Ø 3.3mm	2 x Ø 1.95mm
Cross-lighter		0.026	0.016
Pilot Injectors		SIT51	SIT35
Supply Pressure	mbar	20	37
Operating Pressure	mbar	11.2	34.5

G3865F INJECTOR SIZES & PRESSURE			
		NATURAL GAS	PROPANE
G3865F main burner injector		4 x Ø 2.38mm	4 x Ø 1.47mm
Cross-lighter		2x0.026	2x0.016
Pilot Injectors		2xSIT51	2xSIT35
Supply Pressure	mbar	20	37
Operating Pressure	mbar	13*	35.6

*Burner pressure should be set with both pans on.

6.4 HEAT INPUT TABLE

HEAT INPUTS (NATURAL GAS AND PROPANE)		
APPLIANCE	kW _{net}	Btu/hr _{gross}
G3860F	30	112,600
G3865F	2 x 16.7	2 x 62,700

7.0 DIMENSIONS / CONNECTION LOCATIONS

7.1 G3860F FRYER.

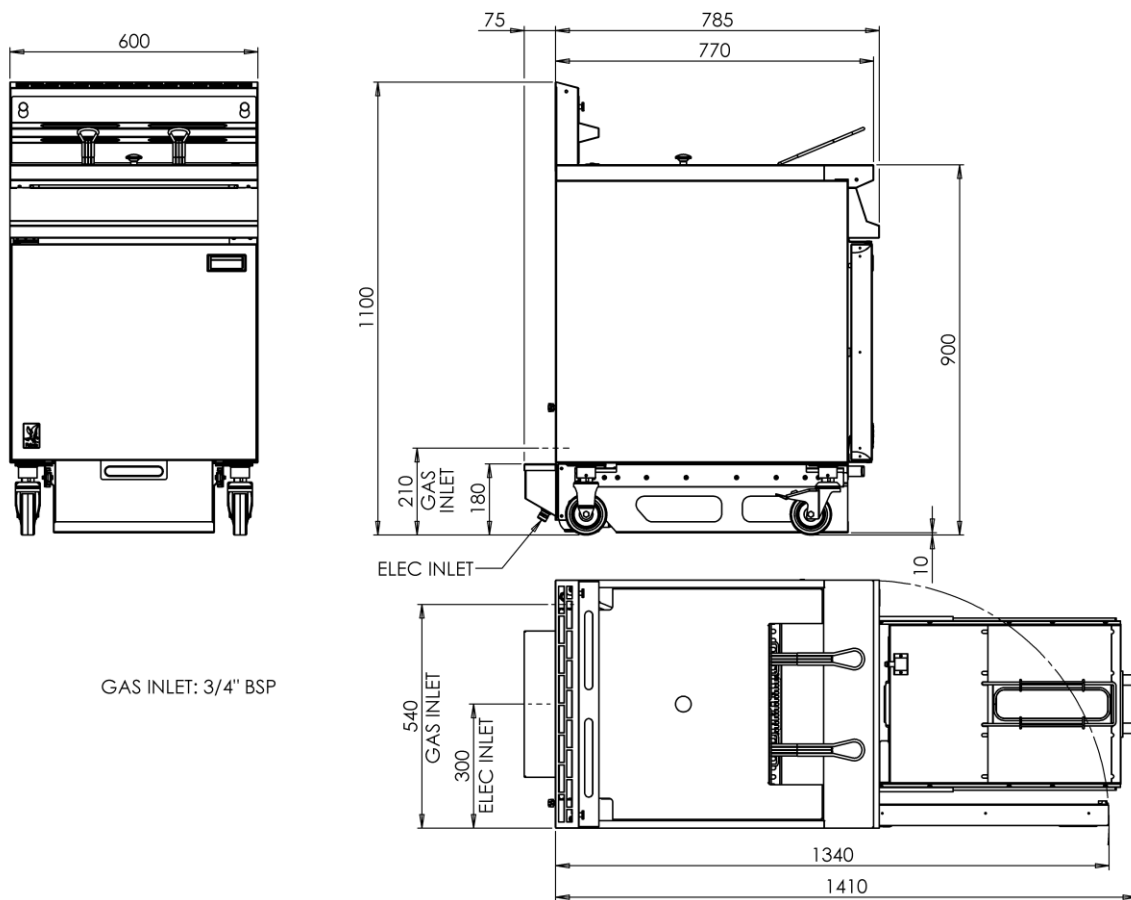

7.2 G3865F FRYER.

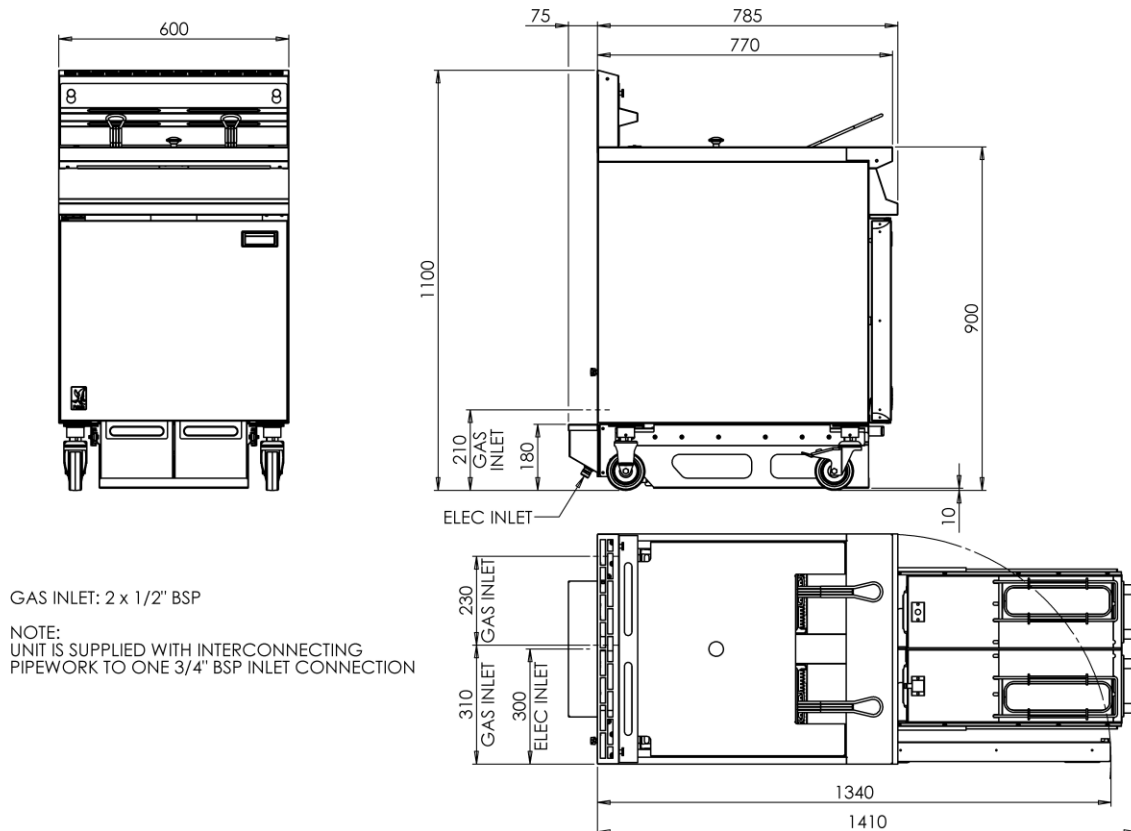

8.0 INSTALLATION

Electrical Safety and Advice Regarding Supplementary Electrical Protection

Commercial kitchens and foodservice areas are environments where electrical appliances may be located close to liquids, or operate in and around damp conditions, or where restricted movement for installation and service is evident.

The installation and periodic inspection of the appliance should only be undertaken by a qualified, skilled and competent electrician; and connected to the correct power supply suitable for load as stipulated by the appliance data label.

The electrical installation and connections should meet the necessary requirements to local electrical wiring regulations and electrical safety guidelines.

We recommend:-

- Supplementary electrical protection with use of a type A residual current device (RCD).
- Fixed wiring appliances incorporate a locally situated switch disconnecter to connect to, which is easily accessible for switching off and safe isolation purposes. The switch disconnecter must meet the specification requirements of IEC 60947.

8.1 SITING / CLEARANCES

UNLESS OTHERWISE STATED, PARTS WHICH HAVE BEEN PROTECTED BY THE MANUFACTURER ARE NOT TO BE ADJUSTED BY THE INSTALLER.

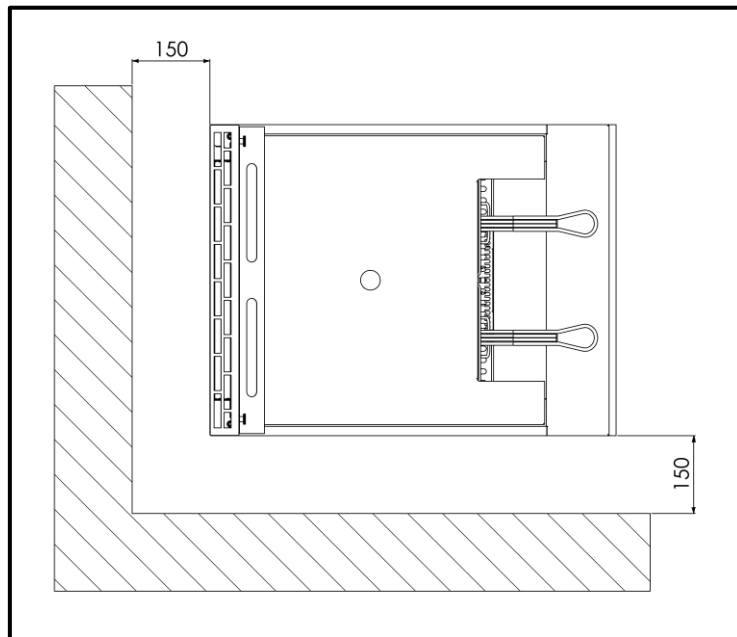

CAUTION: WALLS CLOSER THAN 150mm TO THE APPLIANCE MUST BE NON COMBUSTABLE. IF SITING THE NECESSARY CLEARANCES TO ANY CUMBUSTIBLE WALL MUST BE THE LARGEST FIGURE GIVEN FOR INDIVIDUAL APPLIANCES INSTRUCTIONS.

THE LOWEST POINT OF THE OIL BUCKET CARRIAGE MUST BE AT LEAST 10MM ABOVE THE FLOOR.

8.2 VENTILATION

This appliance must be installed with sufficient ventilation to prevent the occurrence of unacceptable concentrations of substances harmful to health in the room in which they are installed.

A competent installer **MUST** be used and be carried out in accordance with local and national regulations which apply at time of the installation.

Recommendations for Ventilation for gas appliances of rated input not exceeding 70kW_{net} (1st, 2nd, and 3rd family gases) are given in BS 5440:2.

For multiple appliances the requirements for individual units must be added together.

8.3 ASSEMBLY

8.3.1 Position the appliance and level using feet adjusters as shown below.

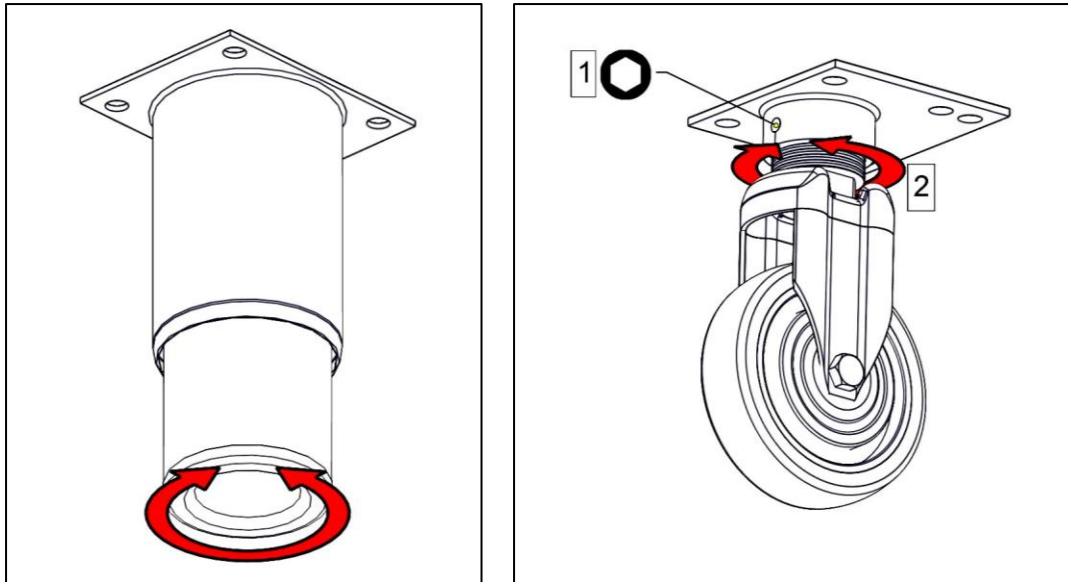

TAKE CARE WHEN MOVING AN APPLIANCE FITTED WITH CASTORS.

8.3.2 Connect appliance to gas supply and test for gas tightness (see section 8.4)



This appliance is also provided with a terminal for connection of an external equipotential conductor. This terminal is an effective electrical contact with all fixed exposed metal parts of the appliance and shall allow the connection of conductor having a nominal cross-section area of up to 10mm². It is located at the rear of the unit and identified by the following label and must only be used for bonding purposes.

8.4 GAS SUPPLY & CONNECTION

8.4.1 Installation pipe work should be fitted in accordance with local / national standards such as IGE/UP/2. The pipework must not be smaller than unit gas inlet connection. If using flexible hosing, the hose must be sized to conform to BS 6173 and the length must not exceed 1.5m. An isolating valve must be located close by for shutdown during an emergency or servicing. An inlet manifold is supplied with G3865F twin-pan models to enable connection to 3/4" BSP inlets.

8.4.2 If flexible hose is used, it shall comply with national requirements. These must be periodically examined and replaced as necessary. A retention chain must also be attached to the rear of the appliance.

8.4.3 **Natural Gas Appliance** - Supplied governor must be fitted to the rear of the appliance.

8.4.4 The installation should be checked for gas tightness and purged as specified in IGE/UP/1.

8.5 ELECTRIC SUPPLY & CONNECTION

A suitable supply cord is supplied that conforms to BSEN 50525-2-11, cable type H05VV-F. This appliance is designed to, and must, be connected to suitably rated isolator. It is recommended that the isolator be rated to 230V at 13A, with contact separation of at least 3mm in all poles. If cord is damaged, it must be replaced by a suitably qualified person.

Live 1 (Phase 1)	Brown
Neutral	Blue
Earth	Yellow/Green



THIS APPLIANCE MUST BE EARTHED.

8.6 COMMISSIONING

Refer to section 2.2 Installation Safety and 4.0 for operation. If safety thermostat is activated, refer to section 4.6 Safety Reset

Carry out the following operation:

8.6.1 Turn the main gas supply on to the appliance.

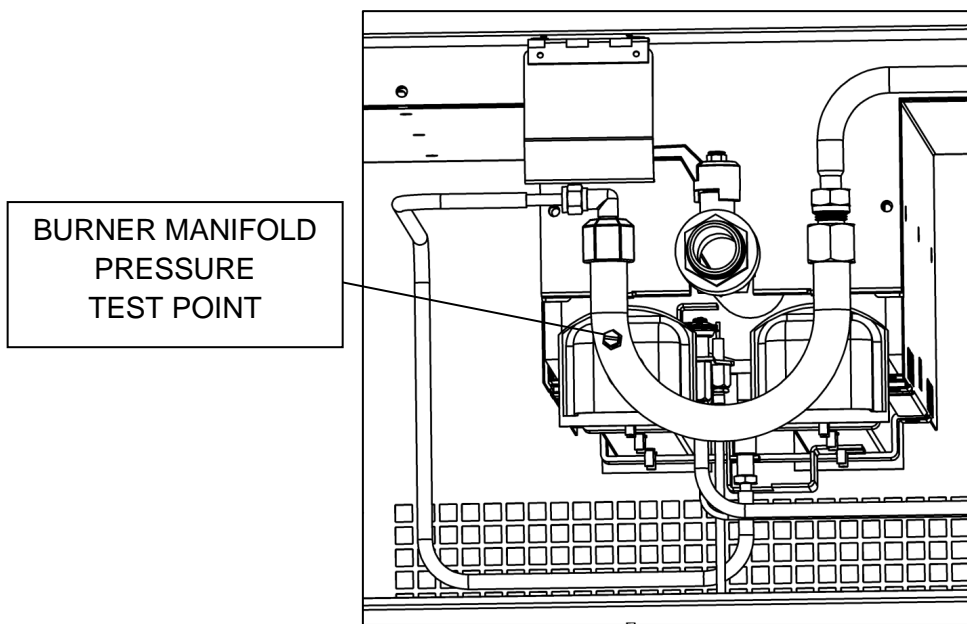

8.6.2 Connect a suitable pressure gauge to the pressure test point on the burner manifold and ensure the burner operational pressure is correct (see section 6.3 for gas pressures).

8.6.3 **Natural Gas Appliance only** – Adjust Governor as shown in section 10.10.

8.6.4 Fill pan with cold oil to the MIN mark.

8.6.5 Light pilot(s) and ensure they stay lit.

8.6.6 Turn on main burner(s) and check for smooth and rapid cross-lighting, good flame stability and flame picture.

8.6.7 Checking the user thermostat calibration: Using a reliable thermometer with measurement tip immersed 25mm below oil surface at centre of pan.

Set the temperature control to 190°C. Measure oil temperature during heat-up from ambient.

The temperature reading when main burner goes OFF should be:

G3830 and G3865	178-188°C
G3860	180-188°C

8.6.8 Switch appliance off. Disconnect pressure gauge and replace sealing screw and check for gas tightness.

If the appliance does not operate correctly, please refer to section 10.0 and rectify the problem.



PLEASE FILL OUT THE INFORMATION TABLE ON THE FRONT COVER AFTER COMMISSIONING. HAND INSTRUCTIONS TO RESPONSIBLE PERSON.

9.0 CONVERSATION



BEFORE INSPECTION, SERVICING OR CONVERSION, TURN OFF GAS AT ISOLATOR.

Identify and check Injector sizes provided in conversion kit (see table section 6.3).

9.1 GAS CONVERSION CHECK LIST

- Change injectors in burner(s), cross-lighter(s) and pilots(s) (see 10.5 & 10.6).
- Change gas type label(s).
- For natural gas (G20) an appliance governor is required to be fitted.
- For Propane (G31) an appliance governor is not required to be fitted.

Once unit has been converted, the installation should be checked for gas tightness and purged as specified in IGE/UP/1.

Finalise conversion by carrying out commissioning checks and tests (see section 8.6).

10.0 SERVICING

SERVICE INFORMATION

This unit carries an extensive mainland UK warranty. The warranty is in addition to and does not change your statutory or legal rights.

The warranty policy can be found on our website which details the conditions of the warranty and the exclusions.

<https://www.falconfoodservice.com/info-centre/policy>



Service calls to equipment under warranty will be carried out in accordance with the conditions of sale.

Warranty calls can be made between 8:30 am and 5:00 pm weekdays only.

To ensure your warranty enquiry is handled as efficiently as possible, ensure you have the following appliance information prior to calling us:

1. Model number – found on data plate
2. Serial number – found on data plate
3. Brief description of the issue

To contact Falcon for a warranty issue dial (UK only) 01786 455 200 and select Warranty Issues from the menu.



BEFORE ATTEMPTING ANY MAINTENANCE, ISOLATE THE APPLIANCE AT THE MAINS SWITCH AND TAKE STEPS TO ENSURE THAT IT IS NOT INADVERTENTLY SWITCHED ON.



BEFORE INSPECTION, SERVICING OR CONVERSION, TURN OFF GAS AT ISOLATOR.



PREVENTATIVE MAINTENANCE CONTRACT

To obtain maximum performance from this unit regular servicing of the appliance should be undertaken to ensure correct operation, it is functioning as intended, and safe to use. We recommend servicing in accordance with SFG20 Maintenance Schedules and as a minimum, after 2,500 hours of use, or annually, whichever comes first and that a maintenance contract be arranged with an appointed service contact. Visits may then be made at agreed intervals to carry out adjustments and repairs.

10.1 CONTROL PANEL

10.1.1 Remove the control panel to gain access to the control components.

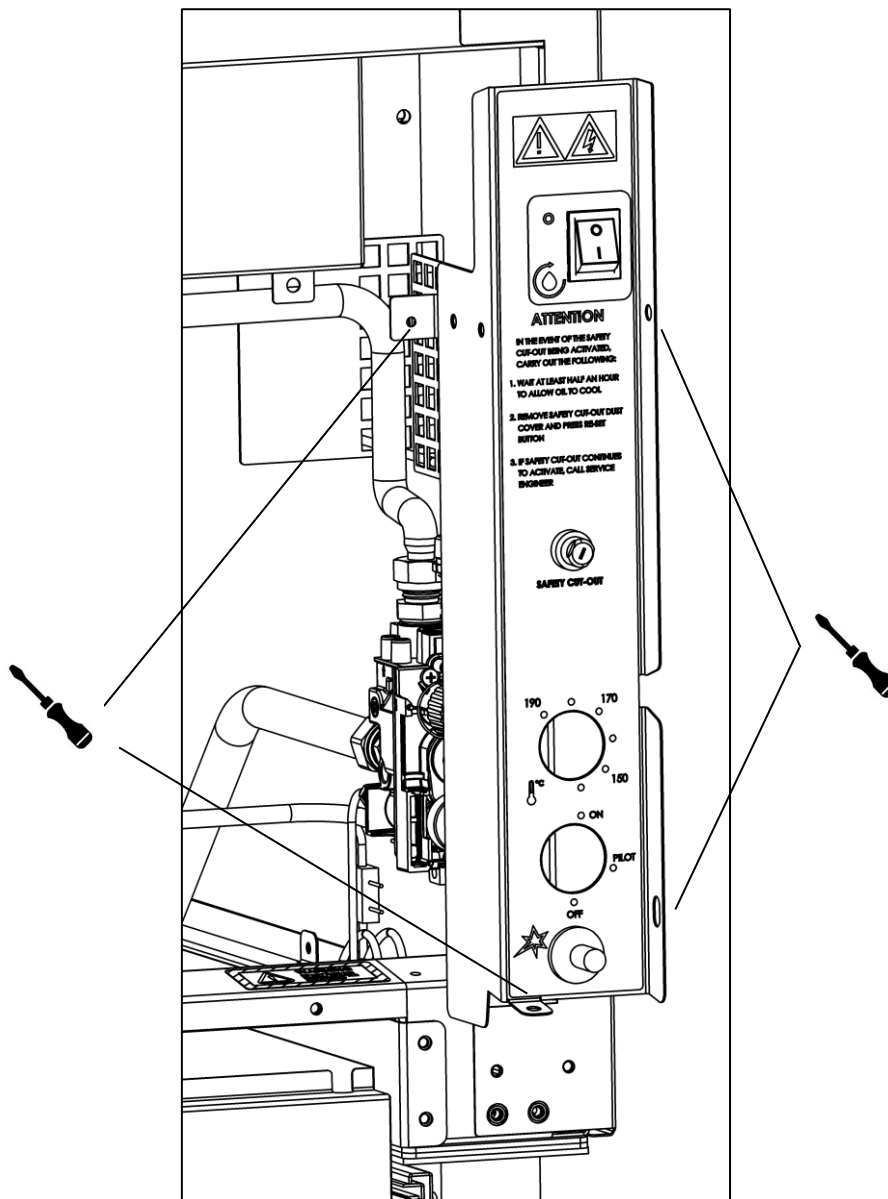

WHEN RE-FITTING, MAKE SURE MAIN BURNER PIPE IS BENT TOWARDS THE REAR TO CREATE SPACE FOR SAFETY THERMOSTAT TERMINAL CONNECTIONS.

10.2 SAFETY THERMOSTAT

10.2.1 To remove the safety thermostat – first step, remove cover panel then loosen phial capillary pan seal:

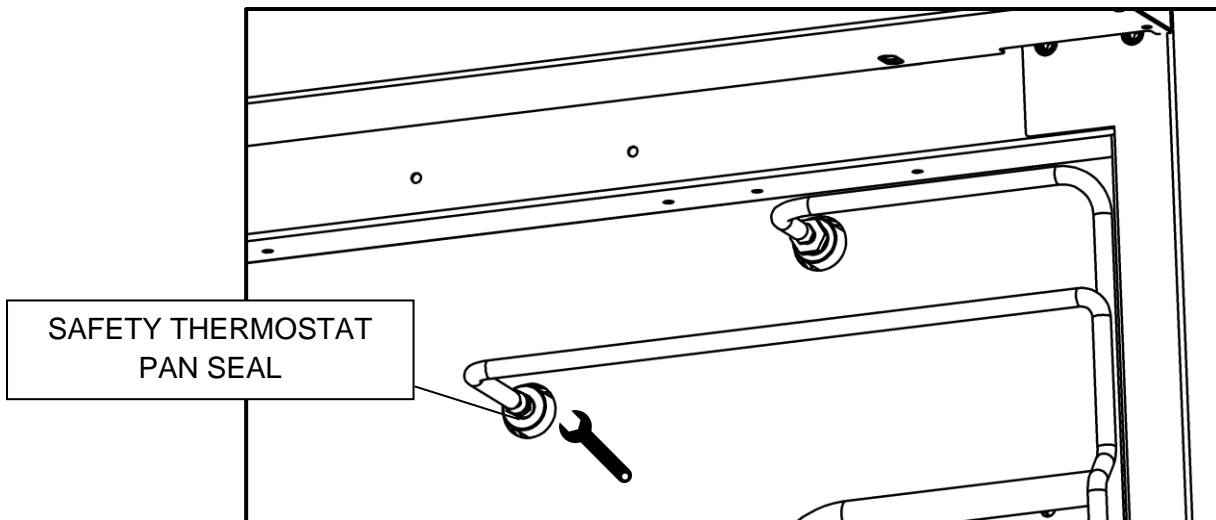
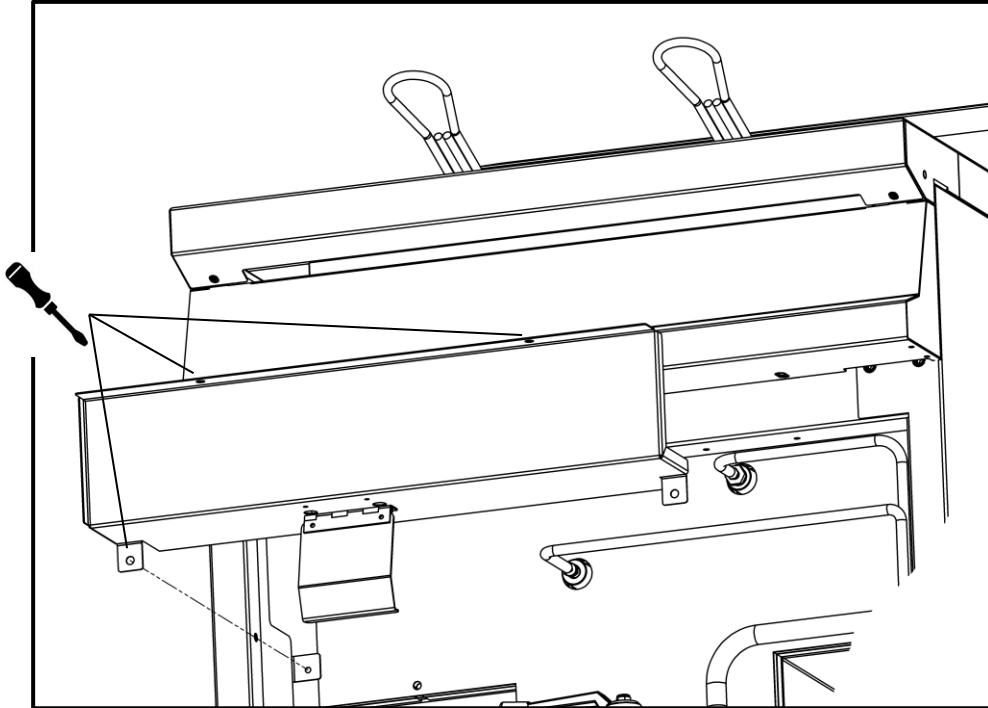

10.2.2 Second step, remove the sleeve nuts holding the phial cover then unclip the phial from the cover. Use a screwdriver to knock the sealing gland out within the pan boss to withdraw the phial from the pan.

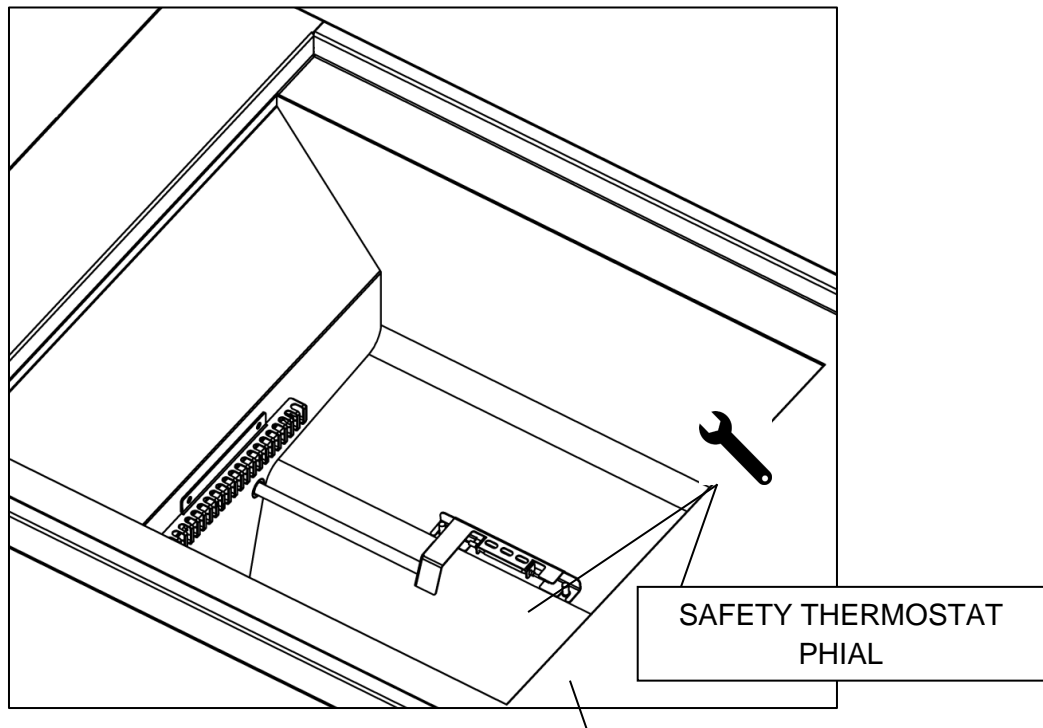

10.2.3 When replacing the phial, apply an appropriate oil and temperature rated sealant on the pan sealing nut to fix it in place.



THE PHIAL AND CAPILLARY TUBE ARE OIL FILLED. INCREASED TEMPERATURE EXERTS PRESSURE ON THE THERMOSTATIC SWITCH WITHIN THE THERMOSTAT BODY.

TAKE CARE TO ENSURE THERE ARE NO SHARP BENDS ON THE CAPILLARY TUBE WHICH WILL AFFECT CORRECT PRESSURE SWITCH OPERATION.

THE CAPILLARY SECTION WITHIN THE CONTROL COMPARTMENT MUST BE FULLY SLEEVED TO PROTECT AGAINST EXCESS HEAT.

10.2.4 To remove safety thermostat body, remove spindle nut that secures thermostat to control panel:

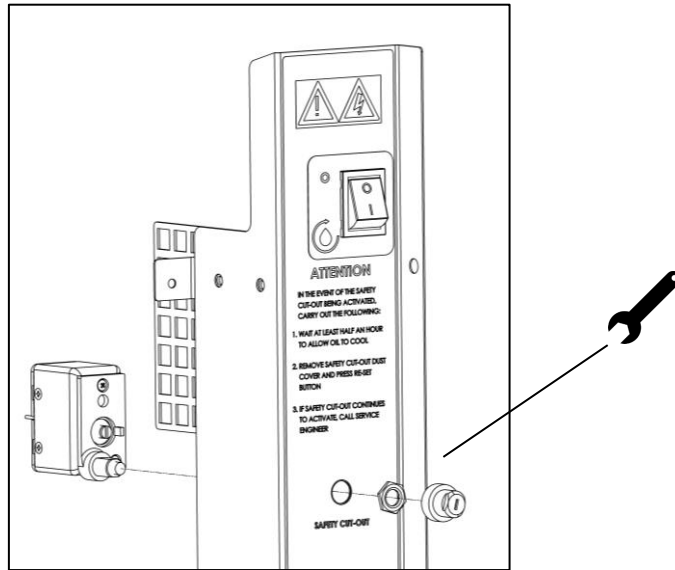

10.3 PIEZO IGNITER AND SPARK ELECTRODE

To remove piezo igniter, pull electrode and earth leads off at rear before removing fixing nut holding the igniter to the control panel.

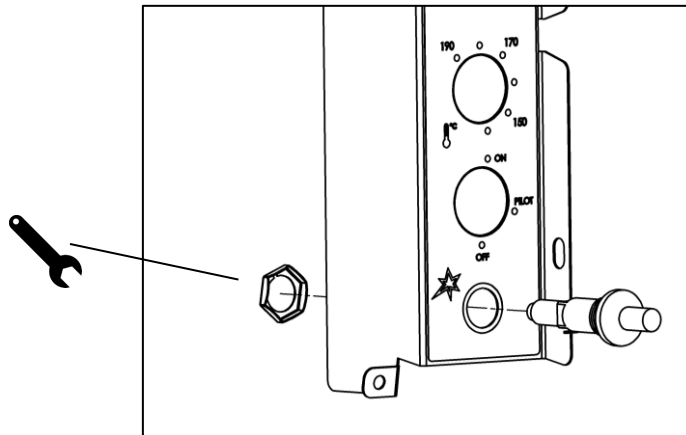

The spark electrode is attached to the pilot assembly. Undo fixing nut to remove as shown below:

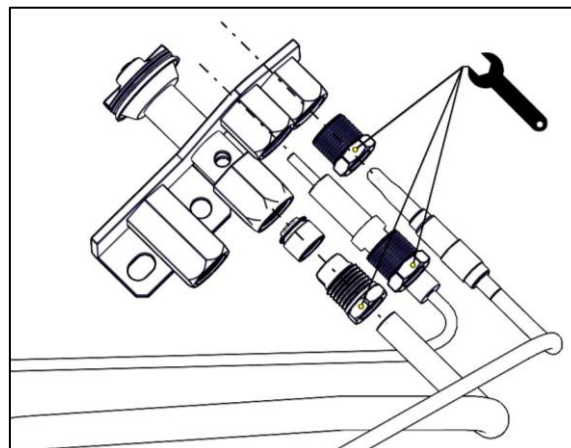

10.4 GAS VALVE

10.4.1 First step - remove cover panel then loosen phial capillary pan seal:

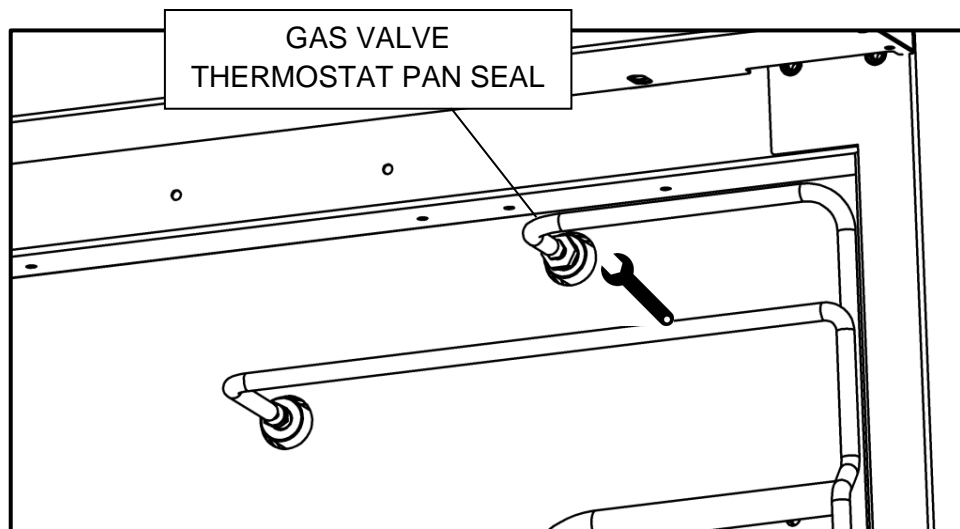
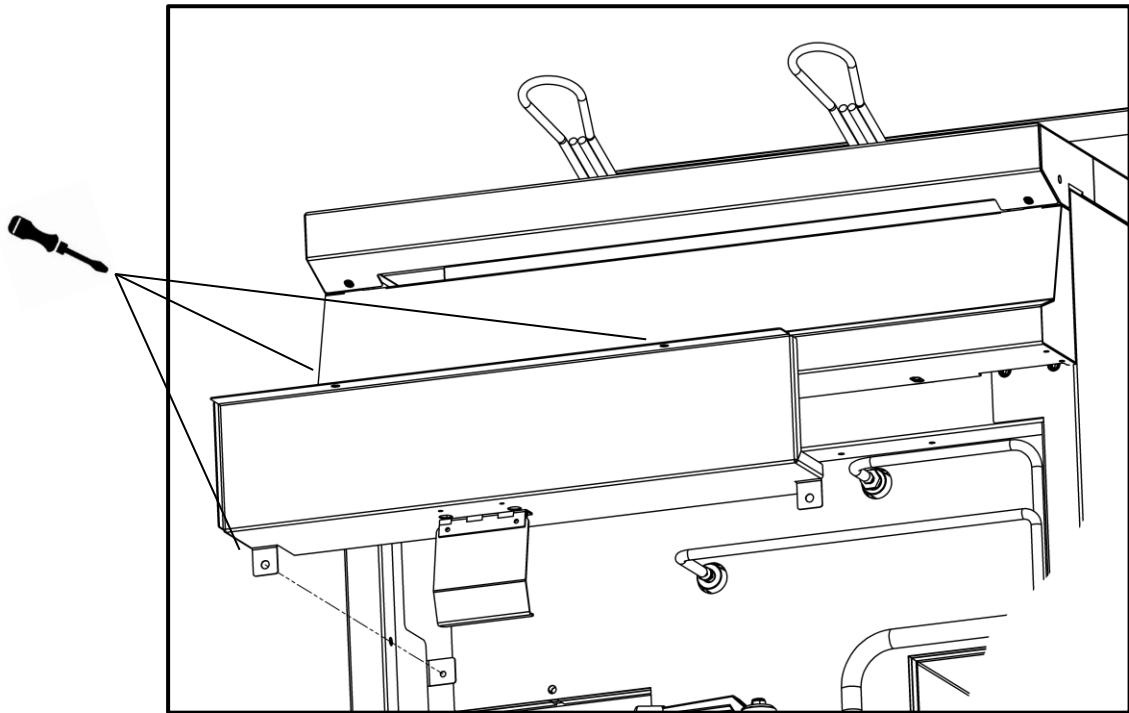

10.4.2 Second step, remove the screws holding the operating thermostat phial cover then unclip the phial from the cover. Use a screwdriver to knock the sealing gland out to remove the phial.

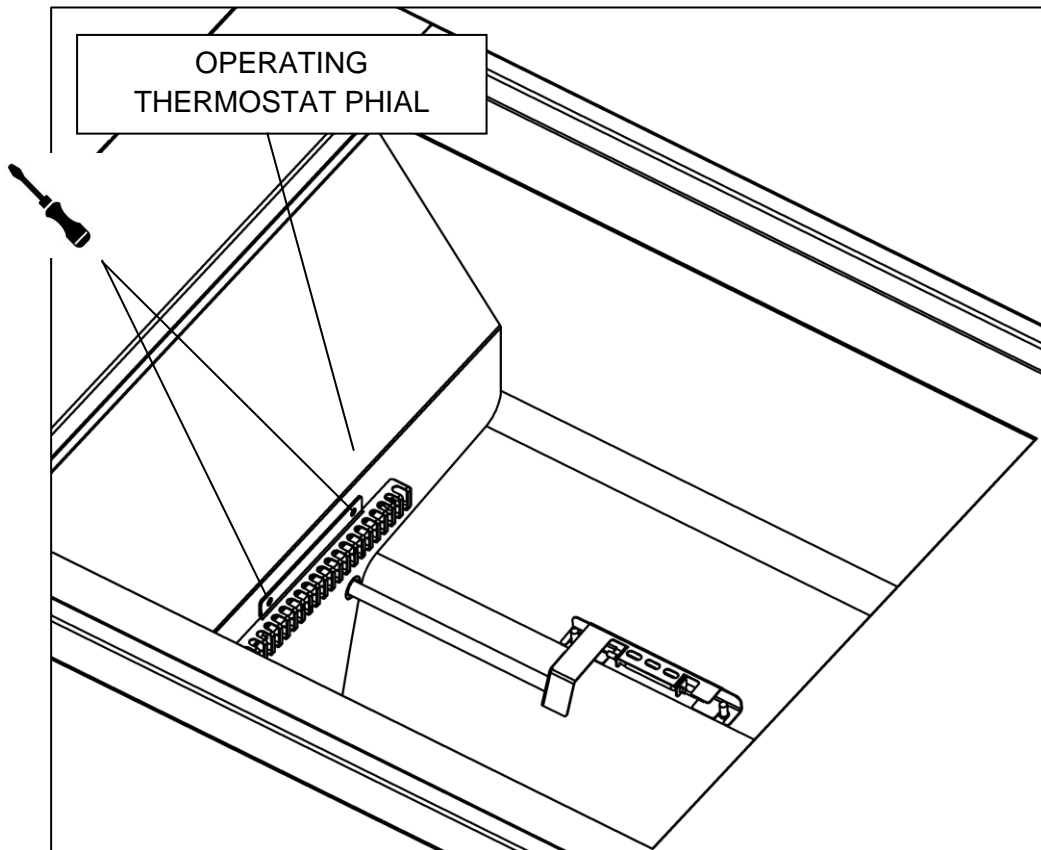

10.4.3 When replacing the phial, apply an appropriate oil and temperature rated sealant on the pan sealing nut to fix it in place.



THE PHIAL AND CAPILLARY TUBE ARE OIL FILLED. INCREASED TEMPERATURE EXERTS PRESSURE ON THE THERMOSTATIC SWITCH WITHIN THE THERMOSTAT BODY.

TAKE CARE TO ENSURE THERE ARE NO SHARP BENDS ON THE CAPILLARY TUBE WHICH WILL AFFECT CORRECT PRESSURE SWITCH OPERATION.

THE CAPILLARY SECTION WITHIN THE CONTROL COMPARTMENT MUST BE FULLY SLEEVED TO PROTECT AGAINST EXCESS HEAT.

10.4.4 To remove the gas valve from the gas pipework first undo main burner pipe compression fitting. Remove the 4 screws that hold the gas valve to bracket and bracket to appliance structure to allow valve to be pulled forward and give better access to rear pipework and thermocouple connections. See illustration below.

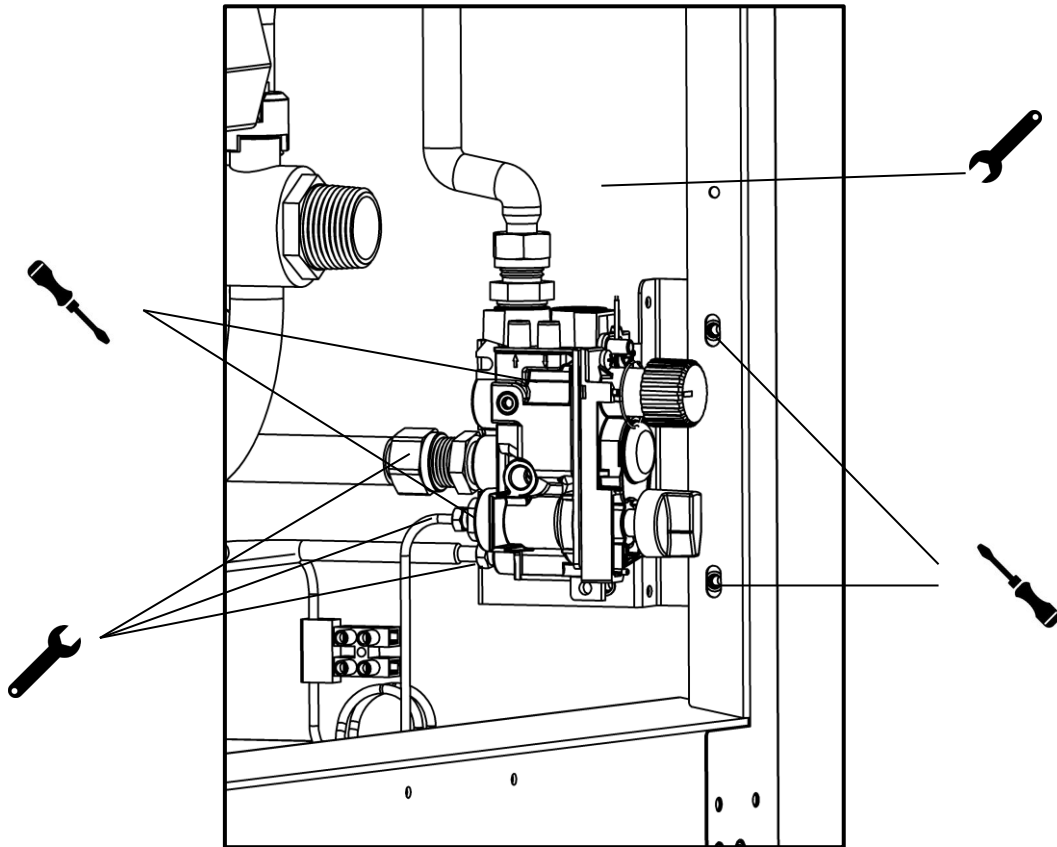

WHEN RE-FITTING THERMOCOUPLE TO VALVE, TIGHTEN WITH TORQUE SETTING 1-2Nm. TAKE CARE NOT TO OVER-TIGHTEN.

MAKE SURE MAIN BURNER PIPE IS BENT TOWARDS THE REAR TO CREATE SPACE FOR SAFETY THERMOSTAT TERMINAL CONNECTIONS WHEN CONTROL PANEL IS RE-FITTED.

10.5 PILOT ASSEMBLY

10.5.1 Remove the fixings holding the pilot assembly to the underside of burner and drop the entire assembly including bracket down to gain access to fixing screws.

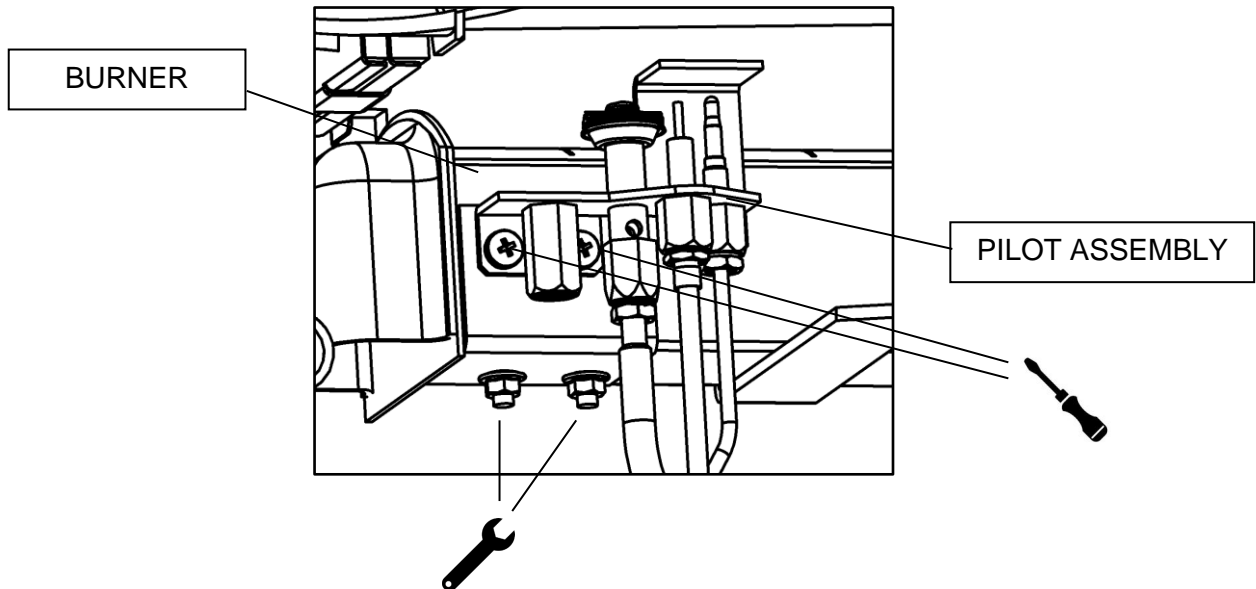

10.5.2 Pilot gas pipe/injector, thermocouple and electrode can now be removed.

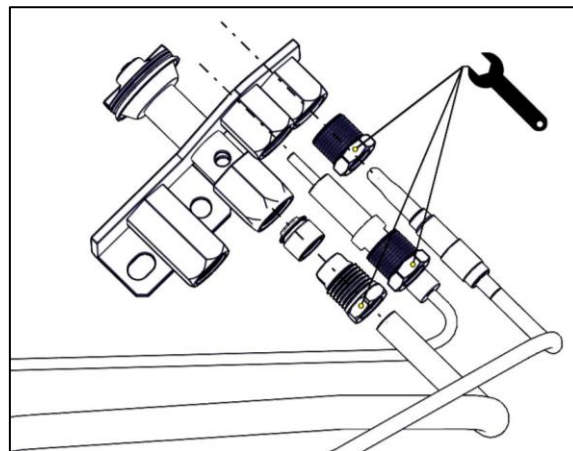

WHEN RE-FITTING THE PILOT ASSEMBLY, THE ELECTRODE CABLE AND THERMOCOUPLE MUST BE ROUTED ALONG THE PILOT PIPE AND NOT LOOPING INSIDE THE UNIT.

THE VIDAFLEX SLEEVING MUST BE ON THE CABLE.

EXCESS THERMOCOUPLE LENGTH SHOULD BE NEATLY LOOPED EITHER SIDE OF THE INTERRUPTER CONNECTOR BLOCK AT A LOOP DIAMETER NOT LESS THAN 30mm.

10.6 BURNER

- 10.6.1 Remove fixings that secure pilot and cross-lighter assemblies to main burner and drop the assemblies slightly.
- 10.6.2 Disconnect the compression joints above manifold.
- 10.6.3 Undo burner bracket fixings that retain burner assembly front cross strap to side runners.
- 10.6.4 Pull burner assembly forward and drop slightly to clear the front strap. While supporting the weight of the assembly, push it back to clear rear strap from runners. Lower and withdraw.

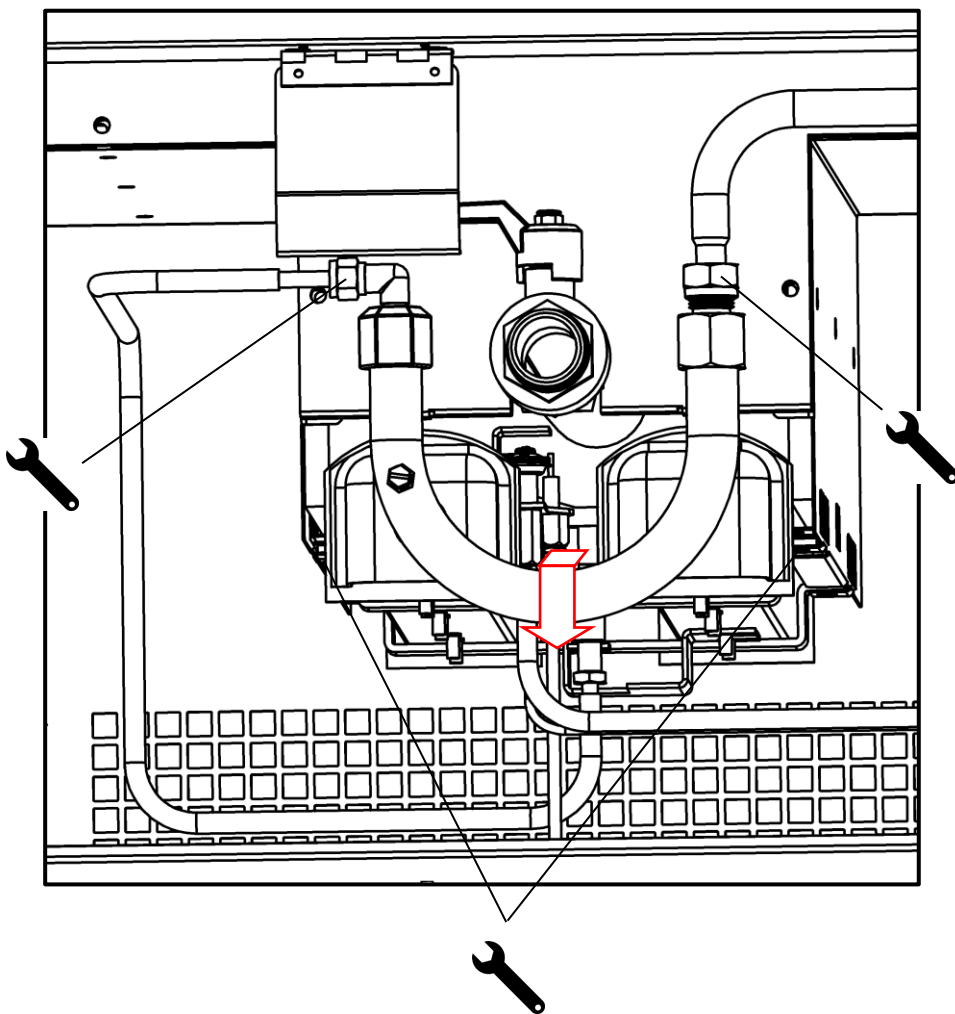

10.7 PUMP SWITCH

10.7.1 Remove the control panel as shown in 10.1.

10.7.2 Remove the wire from the pump switch noting their position.

10.7.3 Depress retaining clips and remove switch.

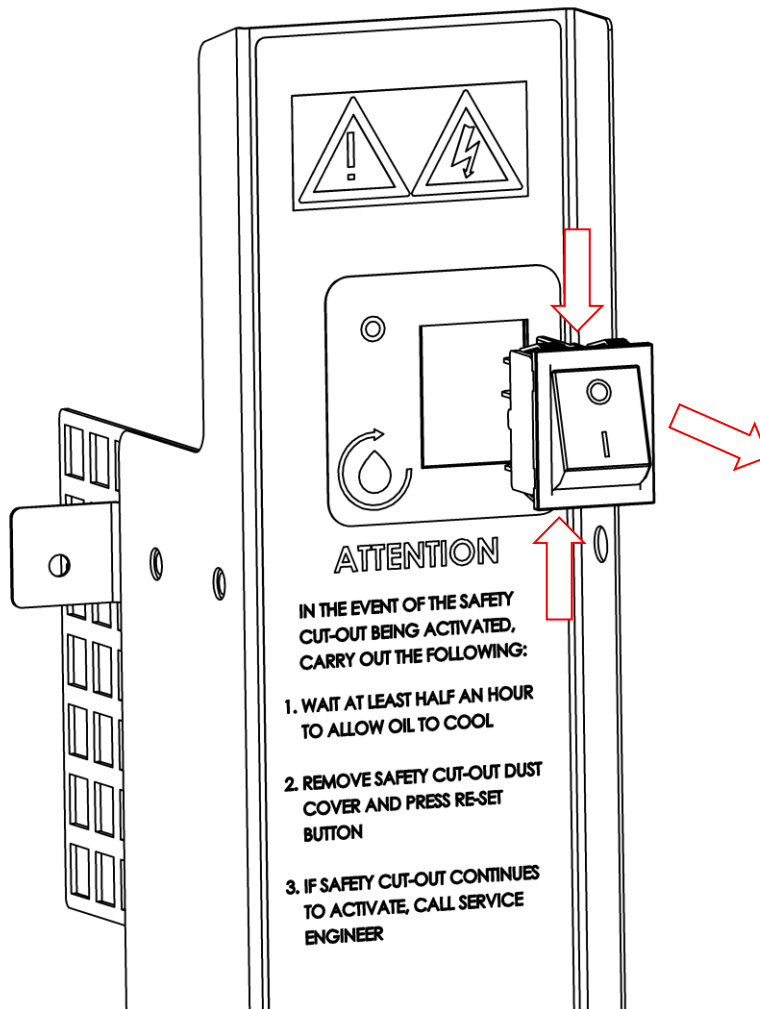

10.8 PUMP

10.8.1 Remove the rear access panel. electrical box cover.

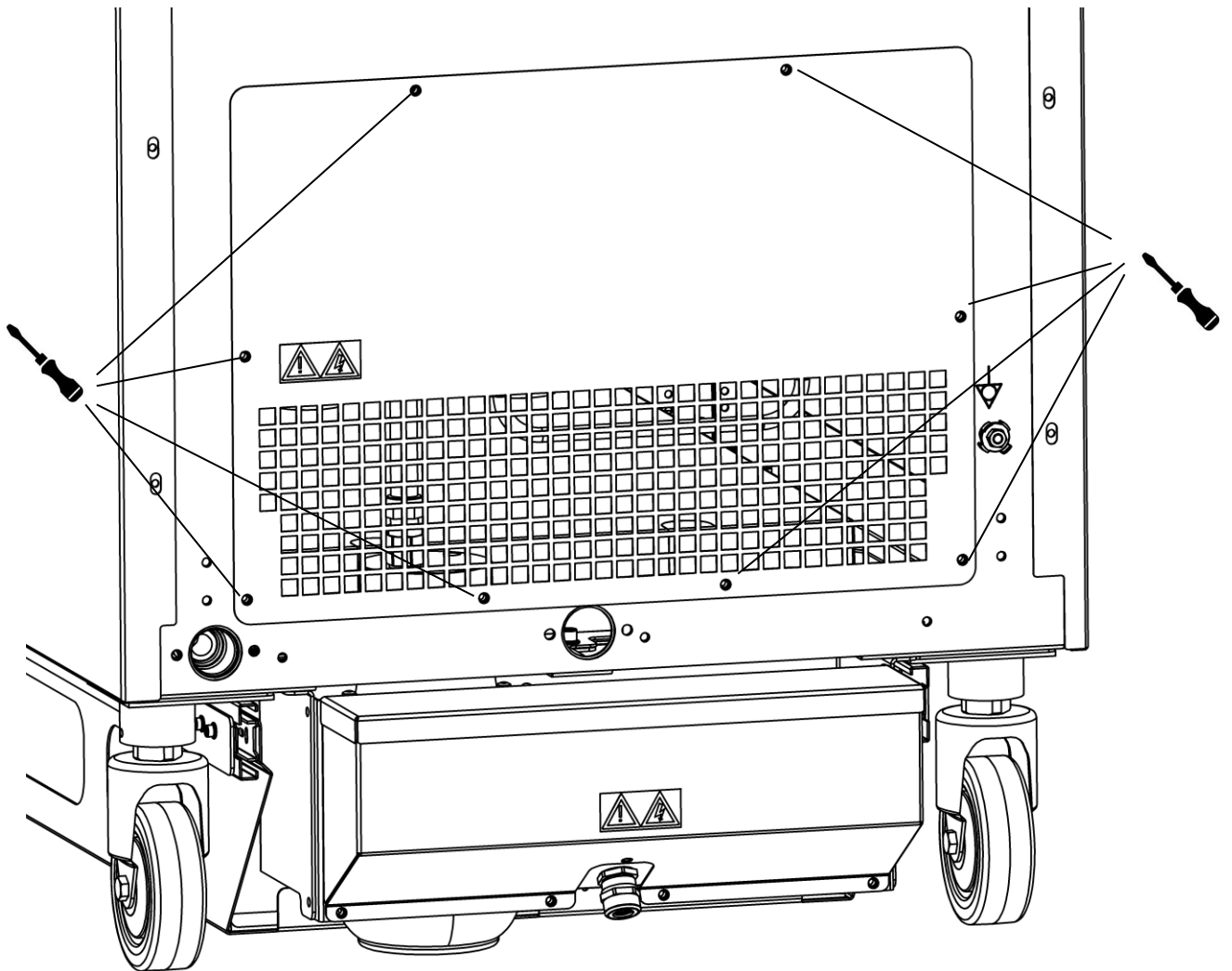

10.8.2 Remove electrical box cover to gain access to the pump timer and electrical components.

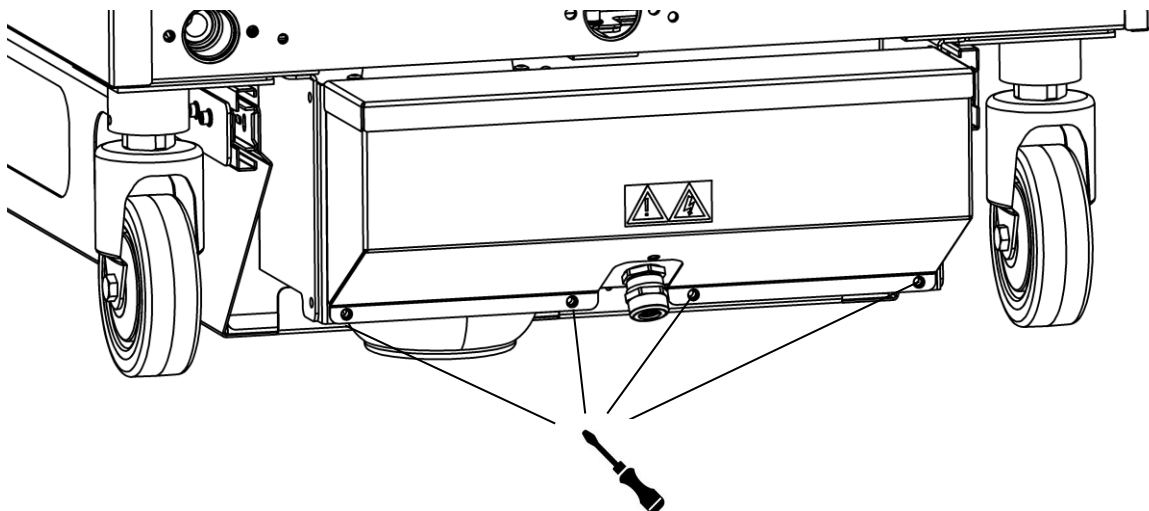

10.8.3 Disconnect the filtration flexi hose from the pump.

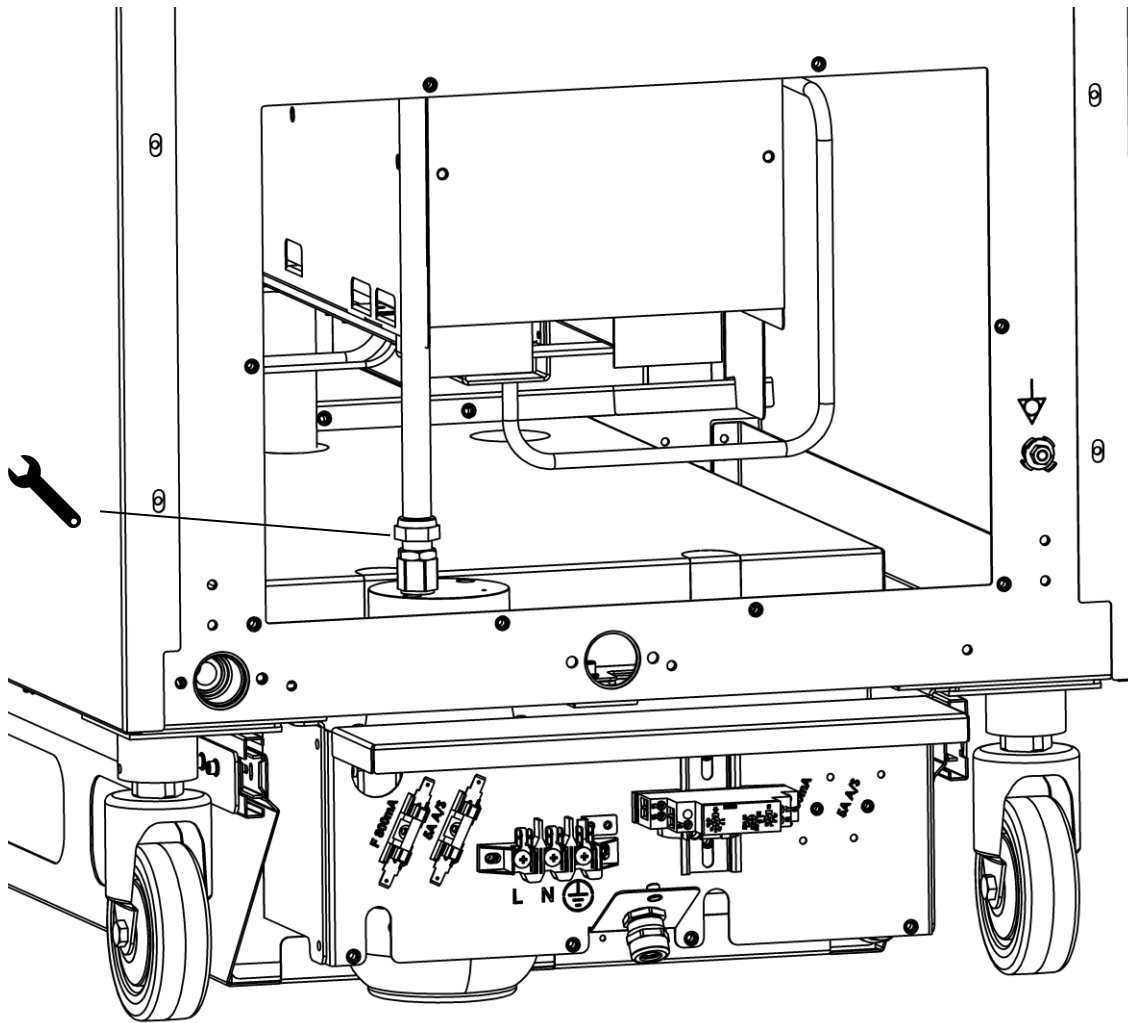

10.8.4 Disconnect the electrical coupling plug located inside the electrical box.

10.8.5 Remove the nut securing the pump capacitor.

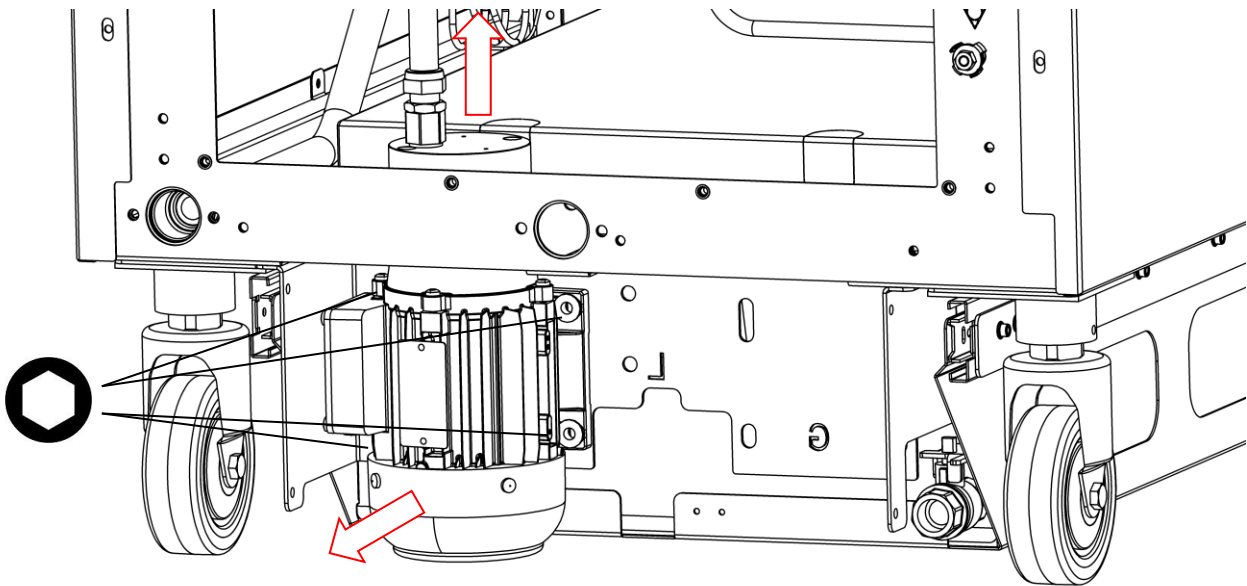

10.8.6 Remove pump mounting bolts and lift pump clear taking the capacitor with it.

10.8.7 Replace pump in reverse order.

10.8.8 Check for leaks before replacing any panels.

Note: The G3865F is fitted with two pumps.

10.9 PUMP TIMER SETTING

10.9.1 Set top function to "0.8".

10.9.2 Set middle function to "10" minutes

10.9.3 Set base function set to "Wu".

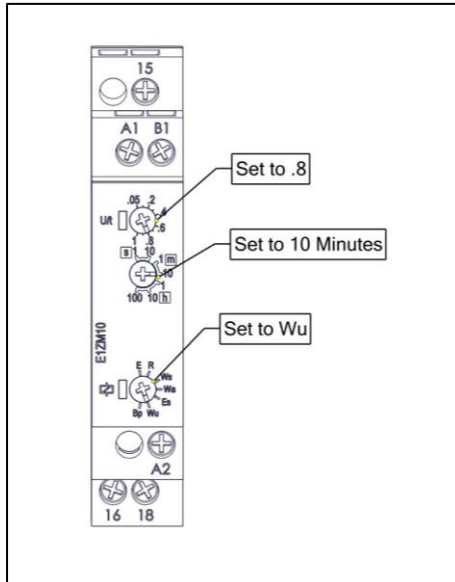

10.10 GOVERNOR

10.10.1 **Natural Gas Appliance only** – Adjust Governor as shown.

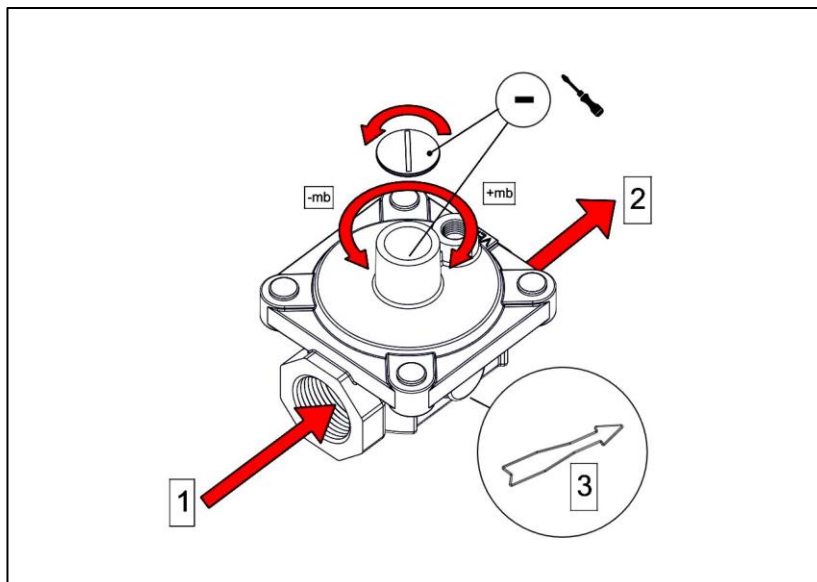

1 – Gas in

2 – Gas out

3 – Direction of flow



GOVERNOR SUPPLIED IS MAINTENANCE FREE. ENSURE THE BLUE DUST CAP COVERING THE VENT IS FITTED AND IN GOOD CONDITION.

10.11 WIRING DIAGRAMS

10.11.1 G3860F Circuit diagram.

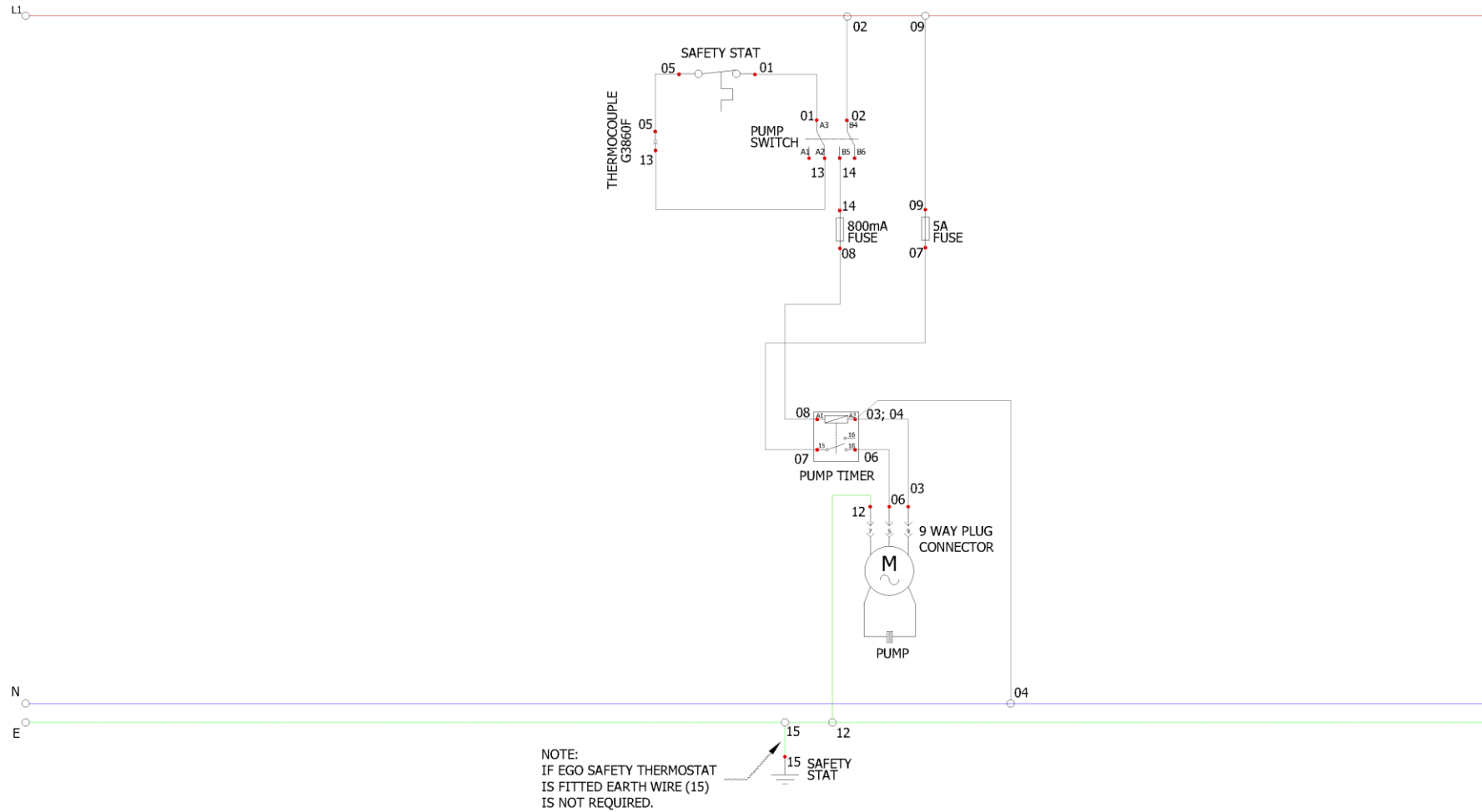

10.11.2 G3865F Circuit diagram.

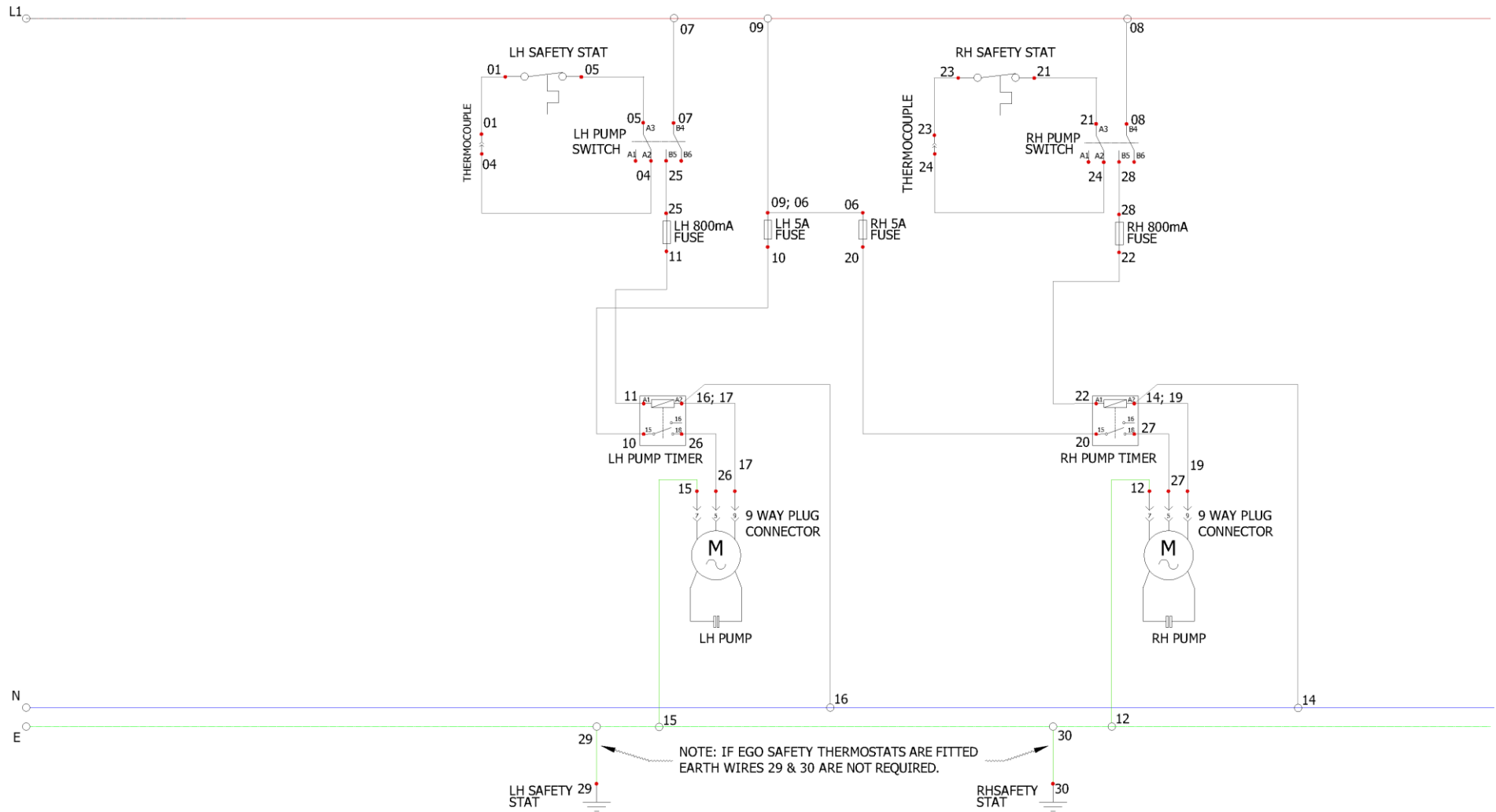

10.11.3 G3860F Wiring diagram.

NOTE:
IF EGO SAFETY THERMOSTAT
IS FITTED EARTH WIRE 15
IS NOT REQUIRED.

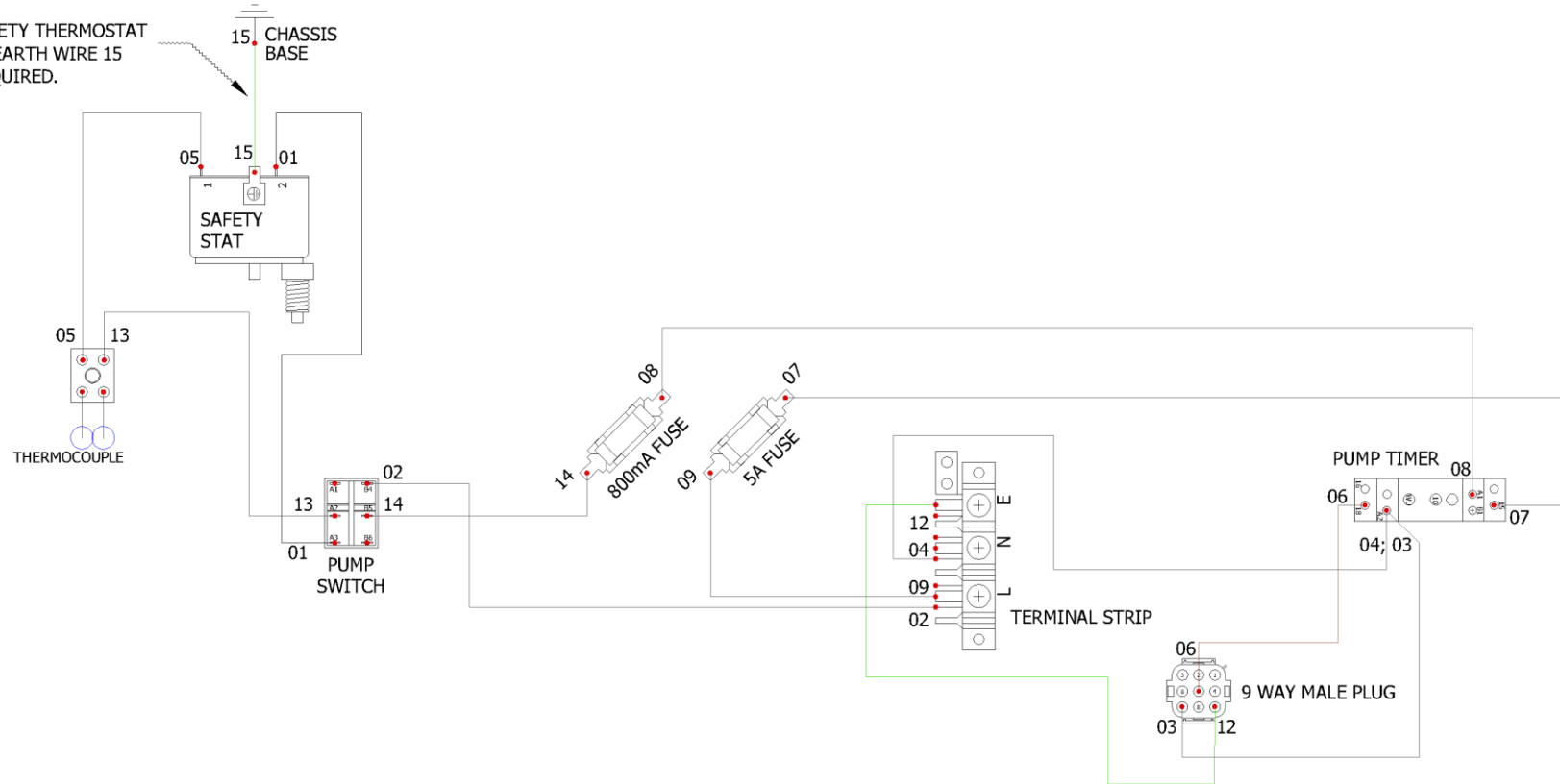

10.11.4 G3865F Wiring diagram.

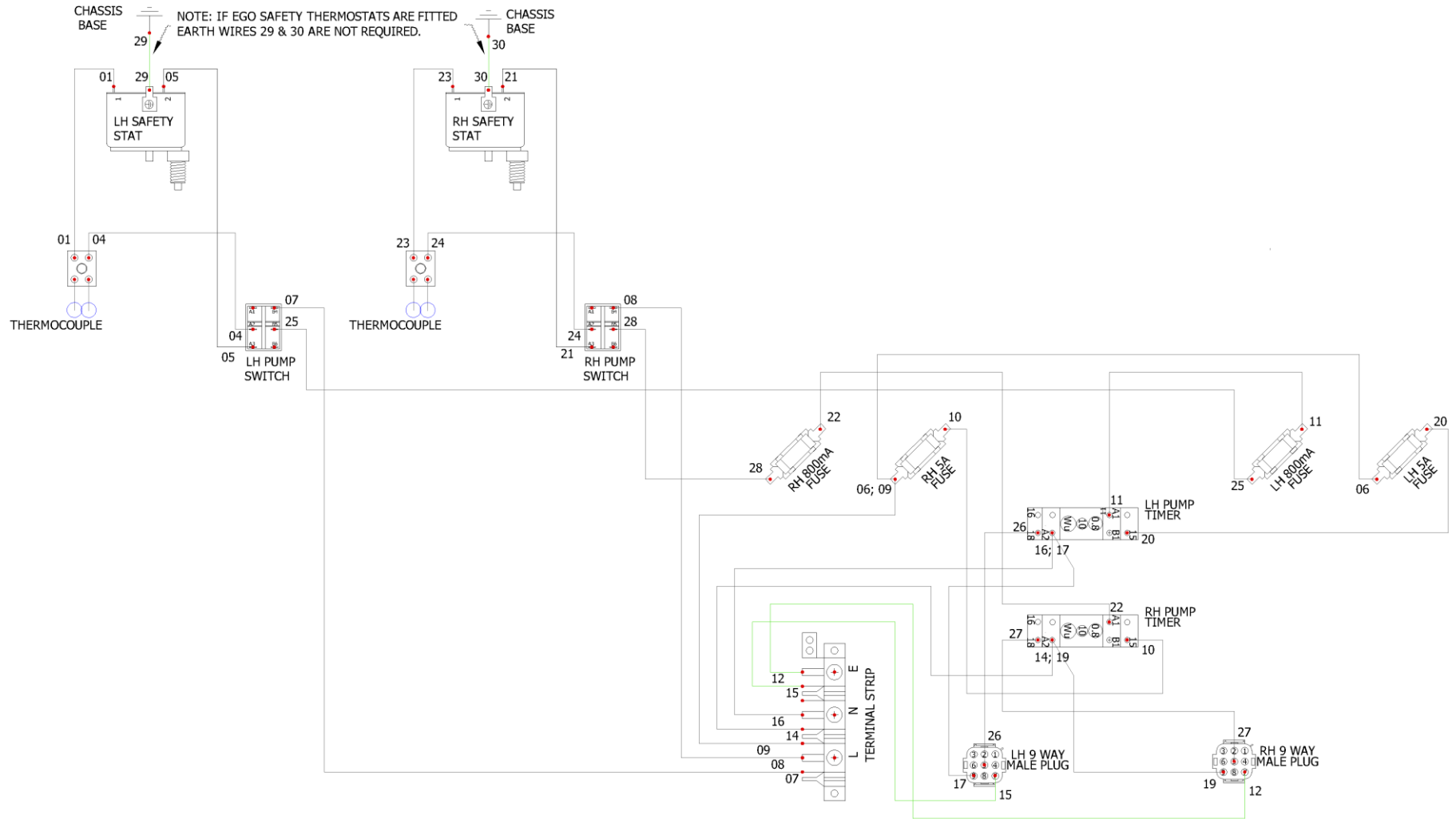

11.0 ACCESSORIES

11.1 SPLASHGUARD

11.1.1 Remove basket hanger and place splashguard on top of the hob. Refit the basket hanger in front of the splashguard to secure them in place.

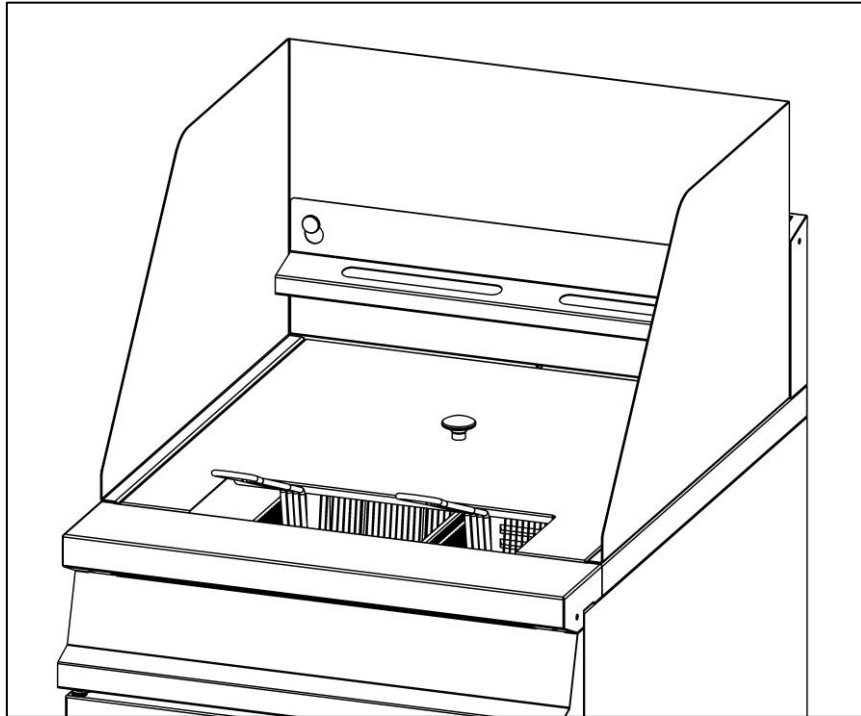

12.0 FAULT FINDING

FAULT	POSSIBLE CAUSES	REMEDY	USER	*ENG
Burner/Pilot will not light/stay lit.	No gas to the unit.	Check main gas is turned on.	✓	
	Safety thermostat has activated.	Reset safety thermostat as per section 2.5 If activates again call service engineer.	✓	
	Blocked injector.	Clean or replace injector.		✓
	Pump switch turned ON.	Switch OFF pump switch.	✓	
Pump not working.	No electrical power to unit	Check mains power is connected and turned on.	✓	
	Fuse has blown.	Investigate and solve the cause then replace fuse at the rear of the unit.		✓
	Pump overheating.	Allow unit to cool for 15 minutes.	✓	
	Pump timer activated after running for 8 minutes.	Switch pump switch OFF then ON again.	✓	
Safety thermostat activated	Low oil level	Add oil to min level mark	✓	
	Burner switched ON without any oil in pan.	Add oil to min level mark. Ensure the pan is never empty when the burner is ON.	✓	
Oil not getting up to the desired temperature.	Faulty thermostat.	Replace thermostat.		✓

PROBLEM	POSSIBLE CAUSES	REMEDY	USER	*ENG
Surge Boiling	Over loading with wet food	Reduce the amount of wet food	✓	
	Overloading with oil	Reduce the amount of oil to the Min Level	✓	
Pan Not Draining	Blocked with debris	Clean drain hole	✓	
Oil not Filtering	Blocked filters with debris	Clean filters inside the oil bucket	✓	
Debris is being returned to pan after filtering	Blocked filters in fryer bucket and overflowing, allowing unfiltered oil back to pan	Ensure oil has time to filter through strainer. Heavily unfiltered oil can block pump	✓	

*ENG Service engineer only.

13.0 SPARE PARTS

PART DESCRIPTION	
Dust Cover	
Basket	
Fry Plate	
Crumb Catcher	
Basket Hanger	
Drain Tube	
Front Facia	
Door Assembly	
Piezo Igniter	
Safety Thermostat	
Gas Valve	

When ordering spare parts please quote the following:

Model Number

Serial number

Gas type

This information will be found on data plate attached to the appliance
Visit our website for further spares information.